

2016



KingTech Turbines - Engine Manual

Series 2

KingTech Turbines
1/29/2017

Table of

What's New	1
PURCHASE AGREEMENT, FULL ASSUMPTION OF LIABILITY AND INDEMNITY AGREEMENT ...	3
KingTech * Limited Lifetime Warranty *	7
Introduction	10
Safety Precautions	12
The Checklist.....	15
Fuel and Oil/ Fuel Care	16
Fuel System	18
UAT (Ultimate Air Trap).....	20
Mounting the Turbine.....	23
Installing the Fuel Pump.....	24
Connections at the Turbine & ECU (G Models).....	25
ECU Battery.....	27
Description of the ECU	29
Setting up the ECU	32
Learn R/C - Teach the ECU Your Radio System	35
Setting the Restart Function	40
Throttle Curves	43
Test/Info Functions	44
Turbine Starting and Running	49
Turbine Stopping and Cooling	52
Run Menu.....	53
Start Menu	58
Summary	65
Turbine Log	68
List of ECU Status Message Codes	72
List of ECU Warning Message Codes:	73
Diagnostic Messages.....	74
K-45G Specifications:	75
K-45TP Specifications:	76
K-60G Specifications:	77
K-60TP Specifications:	78
K-80G Specifications:	79
K-100G Specifications:.....	81
K-120G Specifications:.....	82
K-140G Specifications:.....	83
K-140G2 Specifications:.....	84
K-160G2 Specifications:.....	85
K-180G Specifications:.....	87
K-210G Specifications:.....	88
K-310G Specifications:.....	89
Maintenance cycle includes:	90
G Model Series 2 Components List.....	91
KingTech Turbines Fuel Start Operating Guide:	92
K-60TP Turboprop Operating Guide:	94
TROUBLESHOOTING	97
CONTACT INFORMATION.....	99
Glossary.....	101
Service Request Form	102

What's New



- The KingTech Series 2 turbines have three new components.
 - New KingTech Series 2 self-priming fuel pumps with black anodized case having machined aluminum mounting brackets and priming valve.
- Pump features integrated multiplex connector and led operating indicator light.
 - 3 different size pumps. KP-500V – K-60, K-80, K-100, K-120.
 - KP-600V – K-140, K-160.
 - KP-800V – K-180, K-210, K-310.
 - The "V" designation indicates the pump models having a priming valve. Models without the "V" (Valve) are replacement pumps for turbine models with Xicoy ECUs. Pumps with priming valves may also be used with Xicoy ECUs but priming valves will not be connected to the ECU and will not function.
 - *(Note: K-45 uses MTH pump without self-priming function. KP-500, KP-600 and KP-800 pumps without self-priming valves are available for turbines with Xicoy ECUs.)*



- New KingTech Series 2 ECU with Anodized case with new mounting bracket, and new simplified temp/rpm cable with indexed connector on ECU end and the following operating features:
- P-Valve, pump priming - in a start sequence, during burner on, the ECU will command fuel pump to conduct self priming, by closing the integrated solenoid valve on our new fuel pump to engage a self- looping pump run

- Temperature probe failsafe will allow the turbine to continue to run even when the temperature probe is no longer working
- Auto-restart modes including automatic restart and glider modes.
- Fuel and Gas valve error detection.
- Turbine Cool down and auto-shut off with RX power turned off. This innovative new features saves transmitter batteries from being depleted while turbine cool down is achieved. Receiver batteries are also saved from unnecessary discharge. The problem of forgetting to turn off the receiver and transmitter after cool down is totally eliminated. Power to the ECU is turned off when the cool down sequence is completed.
- ECU Summary data viewable on the GSU detailing last four turbine engine runs with Minimum, Mean, and Maximum values for critical values necessary for troubleshooting.
- ECU Turbine Log data displayed in graphical format with horizontal scrolling through the time of the last four turbine runs. Critical data points displayed in separate colors superimposed on each other to highlight relationships.



- New KingTech Series 2 GSU with bright LCD Touchscreen that is thin and can be mounted inside the RC Aircraft.
- It is recommended if mounting in the aircraft to mount with a single small strip of Velcro for easy removal when trouble shooting

and be sure to leave a service loop of connection cable as well for this purpose.

PURCHASE AGREEMENT, FULL ASSUMPTION OF LIABILITY AND INDEMNITY AGREEMENT

User acquires from KingTech, or from one of KingTech's authorized dealers, a MINIATURE TURBOJET ENGINE for model aircraft, agrees to all of the following terms and conditions:

1. User's Representations. User represents that he/she is very experienced in model airplane operation, and that all of the information set forth is true and correct. KingTech relies on such representations, and would not enter into this transaction but for these representations.
2. User acknowledges the Risks and Dangers involved. User recognizes that operation of the Model Engine may be dangerous, and that under certain circumstances, its handling will be dangerous. As set forth in Paragraph 3 below, User accepts full responsibility for all of these risks and waives all liability against KingTech.
 - a. User's Acknowledgment of Danger. User expressly acknowledges that use of the Model Engine is dangerous if improperly handled, and could inflict injury if attempts are made to handle it properly, if the user does not fully acquaint himself/herself with the Model Engine's operation procedures. The Model Engine may cause burns to the user, or the user's assistant, particularly in the start-up procedure, and user agrees to use extreme caution. The Model Engine exhaust is extremely hot, and will burn someone or something placed directly behind the exhaust tube. Highly flammable liquid is used to operate the Model Engine, and it or its fumes will ignite easily and flare up rapidly. The Model Engine itself remains extremely hot, after it is shut off, and requires a cooling down period. Improper use of the Model Engine, or failure to follow Academy of Model Aeronautics ("AMA") guidelines and rules will result in injury to the user, the user's assistant, or bystanders. Operation of the Model Engine in any location other than an approved location, and under safe circumstances could lead to injury to

bystanders. A risk exists from explosion, in the event of tampering, modifications leading to over-speed or extreme metal fatigue.

b. User's Obligation to Become Fully Acquainted With Operation

Procedure. User acknowledges receipt of operating instructions for the Model Engine which depicts its handling and operation. User agrees to thoroughly acquaint himself/herself with these materials, and to require his/her assistant to become equally familiar with them. User expressly agrees not to allow any person to assist in the start-up procedure of the Model Engine, who has not become thoroughly familiar with these materials.

c. Agreement to Use Qualified Assistant in Start-Up Procedure. User

acknowledges that the start-up procedure for the Model Engine cannot be safely done without an assistant. User expressly agrees to use an assistant, who is thoroughly familiar with the Model Engine and its operation as set forth above, on each occasion when the Model Engine is starting up.

d. Warning to Bystanders. User acknowledges that injury or burns to

bystanders could occur, during the start-up procedure or when operating the Model Engine. User expressly agrees to take all steps necessary to assure that no bystander will be in a position to receive injuries during the start-up procedure, or while the Model Engine is running.

3. Full Assumption of Liability; Waiver and Release of KingTech. User assumes all risks of injury, harm and damages, of every nature whatsoever, to himself/herself and his/her property. User fully and completely waives and releases any and all claims which he/she might have at any time arising out of the purchase, handling, or operation of the Model Engine. This assumption, waiver and release is complete, full, and comprehensive.

a. Release Even If KingTech Is Negligent. The waiver and release contained herein releases KingTech from all conduct, no matter how it could be characterized or alleged. KingTech shall not be liable based on any theory in strict liability in tort. KingTech shall not be liable for any alleged breach of

- warranty, whether express or implied, of any nature whatsoever, whether a warranty of fitness for a particular use, merchantability, or otherwise.
- b. Waiver Effective for All Time. The waiver and release contained herein is effective, without regard to the passage of time. It is effective indefinitely. It will not be changed by any modification to the Model Engine, to any later resold, or other changes in any circumstances.
 - c. Release Extends to KingTech and All Its Associates. The waiver and release contained herein protects KingTech, and all of its employees, officers, principals, owners, importers, distributors, dealers, designers, and agents ("Associates").
4. No Modifications to Model Engine. User agrees to make no modifications of any kind to the Model Engine. This Agreement pertains to the entire life of the Model Engine.
 5. Sale By User to Other Party. User agrees to fully inform any person to whom he/she sells or transfers the Model Engine, concerning the handling, use, and operation of the Model Engine, and agrees to give all operating instructions to such person, at or before the time of sale or transfer. The indemnity and hold harmless agreement contained in Paragraph 3 continues in effect, following such sale or transfer.
 6. Severability. In the event any clause, provision, or term of this Agreement is held to be ineffective, void or otherwise unenforceable for any reason, that clause, provision, or term shall be severed from this Agreement, and the Agreement shall otherwise remain binding and effective. If any portion of Paragraph 3 is found to be unenforceable, then the parties agree that the fullest and most complete waiver and release, which is permitted by law, shall be effective.
 7. No Interpretation of Agreement Against Either Party. User understands and expressly acknowledges that he/she has the right to have an attorney read and review this Agreement, before execution. This Agreement shall not be

interpreted against either party, but shall be interpreted as if it was drafted mutually by the parties.

8. KingTech reserves the right to void warranty to an individual if one chooses to make a negative public announcement before contacting us and allowing us opportunity to assist or correct.
9. Make certain to comply all local rules, and obtain local licensing, permit, or waiver to operate a turbine engine.
10. KingTech Turbines reserves the right to terminate support to those who are defiant and in compliant to our ways of operations.
11. If the Buyer is not prepared to fully accept the PURCHASE AGREEMENT, FULL ASSUMPTION OF LIABILITY AND INDEMNITY AGREEMENT, the Buyer is advised to return this Model Engine immediately in new and unused condition to the place of purchase.
12. Engine sent in for crash repair or misuse is subject to a \$50 inspection fee (inspection fee waived if work is authorized) and return shipping charge.
13. We reserve the right to ensure all repairs are up to factory spec including cosmetics, quality or level of repair is not to be negotiated nor compromised.
14. Any engine sent in not reclaimed within 90 days will be considered abandoned and will be dismantled, disposed or recycled.
14. Terms and conditions may change without notice. Buyers are to accept the latest terms and conditions with no exceptions, which is to be found at:
www.kingtechturbines.com.

KingTech * Limited Lifetime Warranty *

KingTech warrants that this MINIATURE TURBOJET ENGINE for model aircraft, cars or boats ("Model Engine") enclosed with this warranty statement is free from defects in materials and workmanship during normal usage, according to the following terms and conditions.

1. The limited warranty extends to the original purchaser ("Buyer") of the Model Engine and is transferable with no fees during the first year of the original purchase, after the first year, a warranty transfer fee of \$150 is required to any subsequent purchaser / end-user. Though it may still not have the warranty in place, all engines must be registered with us at www.kingtechturbines.com to receive any type of support.
2. Warranty coverage begins the day you bought the turbine to the day you sold or lost the turbine, all electrical components such as batteries, electric starter motor, glow plug, valves, ECU, GSU, pump and all frictional materials and components will have a one year warranty coverage including but not limited to that of the bearings. All parts, including repaired and replaced parts are covered for the original warranty period. When the warranty on the turbine expires, the warranty on all replaced and repaired parts also expires. The engine core, including but not limited to that of combustion chamber, shaft, shaft tunnel, diffuser, injectors, NGV, turbine wheel, will enjoy lifetime warranty and may or may not be replaced or upgraded during interval services.
3. Buyer must fully accept all conditions of the PURCHASE AGREEMENT, FULL ASSUMPTION OF LIABILITY AND INDEMNITY AGREEMENT
4. During the warranty period KingTech will repair or replace, at KingTech's option, any defective parts with new or factory rebuilt replacement items if such repair or replacement is needed because of Model Engine malfunction or failure during normal usage. No charge will be made to the Buyer for any such parts. KingTech will also pay for the labor charges incurred by KingTech in repairing or replacing the

warranted parts and or components. The limited warranty does not cover defects in appearance. KingTech will not be liable for any other losses or damages.

5. Upon request from KingTech, the Buyer must prove the date of the original purchase of the Model Engine by a dated bill of sale or dated itemized receipt.
6. Buyer must bear the cost of shipping the turbine to KingTech, Taiwan or KingTech Turbines International in Pasadena, California.
7. Buyer shall have no coverage or benefits under this lifetime warranty if any of the following conditions are applicable
 - a. The Model Engine has been subject to abnormal use, abnormal conditions, improper storage, unauthorized modifications, unauthorized repair, misuse, neglect, abuse, accident, alteration, improper installation, fail to engage into proper cool down, or other acts which are not the fault of KingTech, including damage caused by shipping.
 - b. The Model Engine has been damaged from external causes such as crash damage, foreign object damage, weather, Act of God, improper electrical connections, or connections to other products not recommend for interconnection by KingTech.
 - c. The Model Engine is operated for commercial or institutional use.
 - d. The Model Engine serial number has been removed, defaced or altered.
8. If a problem develops during the warranty period, the Buyer shall take the following step-by-step procedure:
 - a. The Buyer shall ship the Model Engine prepaid and insured to KingTech, Taiwan or KingTech Turbines International in United States.
 - b. The Buyer shall include a return address, daytime phone number, complete description of the problem and proof of purchase.
 - c. The Buyer will be charged for any parts and/or labor charges not covered by this warranty.
 - d. If the Model Engine is returned to KingTech during the warranty period, but the problem with the Model Engine is not covered under the terms and

conditions of this warranty, the Buyer will be notified and given an estimate of the charges the Buyer must pay to have the Model Engine repaired, with all shipping charges billed to the Buyer. If the estimate is refused, the Model Engine will be returned freight collect plus cost of estimate generally \$50. If the Model Engine is returned to KingTech after the expiration of the warranty period, KingTech's normal service policies shall apply and the Buyer will be responsible for all charges.

9. KingTech shall not be liable for delay in rendering service under the limited warranty, or loss of use during the period that the Model Engine is being repaired.
10. KingTech neither assumes nor authorizes any other person or entity to assume for it any other obligation or liability beyond that is expressly provided for in this limited warranty.
11. This is the entire warranty between KingTech and the Buyer, and supersedes all prior and contemporaneous agreements or understandings, oral or written, and all communications relating to the Model Engine, and no representation, promise or condition not contained herein shall modify these terms.
12. This lifetime warranty allocates the risk of failure of the Model Engine between the Buyer and KingTech. The allocation is recognized by the Buyer and is reflected in the purchase price of the Model Engine.
13. If and when the bearings require replacement and ECU timer set back to zero during a warranty repair, customer is to be responsible for the charges of interval service at a prorated amount for the hours used.
- [14.](#) Terms and conditions of warranty and liability may change without notice; users are to accept the latest terms and conditions with no exceptions.

Introduction

Congratulations, you have just purchased a turbo-jet engine from KingTech Turbines, with the highest standards and technologies in turbine design and manufacturing. We will provide you with the best after-sales customer support and service to ensure you with many years of enjoyment with this new turbine engine. ***Please take a moment to properly register your engine at www.kingtechturbines.com.**

Obviously, model turbine aviation - despite all the apparent fun involved - has its potential dangers. All KingTech turbine engines have been through an extensive period of R&D and testing.

To begin, read this manual thoroughly. Develop an overall impression of the engine and its operating procedures, measuring equipment and accessories.

Study the material step-by-step and ascertain how to install, operate and maintain your turbine engine. If you are unsure about anything, re-read it again or contact us directly.

DO NOT OPERATE THE TURBINE BEFORE YOU HAVE READ THE MANUAL AND FULLY UNDERSTAND EVERY PROCEDURAL DETAIL

Once you are accustomed to handling the Kingtech turbine, you will observe that it is a very reliable engine. Some experienced operators have expressed their belief that it handles better than many piston engines. However, always remember, this is a REAL JET ENGINE, requiring knowledge, discipline and maintenance.

In order to learn more about the development of the model turbine engine and understand its function, we highly recommend reading *Gas Turbine Engines for Model Aircraft* by Kurt Schreckling and *Model Jet Engines* by Thomas Kamps. These books are available through:

Traplet Publications

Traplet House

Severn Drive

Upton upon Severn, Worcestershire ISBN 0 9510589 1 6

United Kingdom WR8 0JL ISBN 0 9510589 9 1

Safety Precautions

ALWAYS ENFORCE THE PROPER MINIMUM SAFE DISTANCES FROM THE TURBINE!

In front of ~ 15 feet, On the side (perpendicular to the engine thrust) ~ 25 feet, Behind ~ 15 feet

Fire extinguishers should be on hand at all times. We recommend the CO2 variety.

To avoid hearing damage, always use ear protection when you are near a running turbine engine.

When the turbine is running, never place your hands into the area of the intake. An extreme suction - which can grasp a hand, fingers or other objects in a flash - prevails in this area. Be aware of this source of danger, always!

Prevent foreign materials from entering the intake or exhaust when working with the turbine. Before operation, make sure there are no loose parts or debris near the turbine or within the fuselage. Objects being sucked in will cause severe damage to the engine, which will not be covered by any warranty; furthermore, such damage may also injuries.

Always exercise caution around the hot parts of the turbine, to avoid burns. The outer case at the turbine stage and nozzle reaches 450-500° (Celsius), while the exhaust gas may exceed 750 °C.

Ensure that the fuel is mixed with approximately 5% approved oil. Use only turbine oils by KingTech Special Blend with Synthetics, which is a non-carcinogenic blend and available at www.kingtechturbines.com or turbine oil with MIL-PRF-23699 available at local airport fuel suppliers.

Never run the turbine in a closed room, or an area near any kind of flammable matter.

Do not fly turbine-powered aircraft near flammable materials, nor in forested tracts or areas experiencing drought or dryness. Obey all forest fire regulations and warnings by refraining from operating turbine in restricted fire zones. Never operate model turbine jet aircraft in or around residential or heavily populated areas.

Installation of unauthorized parts from another manufacturing source may also result in

engine failure.

Warning:

A flying model with a turbine can reach higher flight speeds than ducted fan-powered models, because the turbine's thrust degrades less with higher flight speeds. With attainable flight speeds of up to 200 MPH or over, you can quickly run out of flying space. There is also a danger of developing control surface flutter or mechanical overload, causing the model to fail in flight. When piloting a turbine powered aircraft, one must properly control the throttle. Full power should be used for takeoff or vertical maneuvers and a reduced setting for level or descending flight. Please abide AMA flight rules of maintaining less than 200 MPH at all times.

The Checklist

Before Running the Turbine

- Charge ECU Battery
- Observe all safety precautions on [Safety Precautions](#)
- Prepare fire extinguisher
- Check fuel lines and filter. Make sure they are clean with no restrictions
- Check that the fuel tank vent is unobstructed
- Fill fuel tank(s). Make sure the main and header tanks are full
- Purge Fuel Line, by Test Pump. Take good care not flooding turbine, (Purging fuel line is only necessary after initial set up, and do not get confused with Prime Pump.
- Turn on receiver switch
- Place the model with nose into the wind
- Activate brakes and now you ready to start.

After Stopping the Turbine

- Turn model into the wind. Activate brakes and stop turbine
- After the cooling process (approximately two minutes), turn off receiver switch.
The new ECU will allow you to shut down the engine and receiver as soon as you are back at the pit and it will continue cooling until desired temperature has reached without the RX being powered on.
- In the event that the turbine does not go into the cooling mode, please refer to Turbine Stopping and Cooling 28 for manual activation.

|

Fuel and Oil/ Fuel Care

KingTech engines use Diesel, 1-K kerosene or Jet-A1 for fuel. Fuel must be mixed with 5% KingTech Special Blend or synthetic turbine oil (Aeroshell 500 and all 2-stroke oil are prohibited), or 1 quart of oil in every 5 gallons of fuel. Among the above 3 types of fuel KingTech highly recommends using regular pump Diesel as they are readily available, inexpensive and having a higher energy density and up to 10 to 12% better fuel efficiency. For best result and full core warranty, use KingTech Oil only, it is proven to be the cleanest and has the best lubrication properties for our engines, please refer to the below comparison chart:

Engine Oil Comparison from KingTech Turbines

	Lubrication	Non-Coking	Non-carcinogenic	Eligibility for 25 hr I.S.	Full Lifetime Warranty	No additional labor required
2 Stroke oils	★★★★★	★★★★★	√		*	
Aeroshell 500	★★★★★	★★★★★			*	
Aeroshell 560	★★★★★	★★★★★		√	√	***
BP 2197	★★★★★	★★★★★		√	√	***
BP 2380	★★★★★	★★★★★		√	√	***
JetCat oil	★★★★★	★★★★★	√	√	√	***
KingTech oil	★★★★★	★★★★★	√	√	√	√
Mobil DTE	★★★★★	★★★★★	√	**	√**	√
Mobil Jet II	★★★★★	★★★★★		√	√	***
Tellus 32	★★★★★	★★★★★	√	**	√**	√

* The use of Aeroshell 500 and 2 Stroke oil will void warranty.

** Running Mobil DTE, Tellus 32 or their equivalent would cause excessive bearing noise and failure, recommended to be sent in for service between 15 to 20, hours. Warranty voids beyond 20 hours.

*** Due to excessive coking, up to 1 hour extra labor charge may apply to the use of Aeroshell 560, BP 2197, BP 2380, JetCat oil and Mobil Jet II

Fuel System

When installing the fuel lines on components with barbed connectors, if necessary slightly

heat the tubing and lubricate the barbs before connecting. This will soften the tube slightly, making it much easier to install. Double looping safety wire on all barbed connection is also

required. To remove tubing from barbed connectors, you must cut the tubing off. Be careful not to damage the barbs when cutting off tubing. This could be done by snipping away the tubing material parallel at the fitting. To insert tubing into a Pisco or Festo quick release fittings, put a drop of oil on the outside of the tubing and use firm pressure until you feel the tube snaps in then lightly pull on the front ring and tubing to ensure a good seal. To release, press in on the front ring, while slightly pushing the turning the tubing then pull the tubing out for a clean release.

ALWAYS use a gasoline-compatible stopper. Silicon stoppers swell and leak.

Check your fuel filters every ten or so flights. The filter is installed with the O-ring located toward the fuel pump.

Use caution not to pinch o-ring when assembling filters. We recommend to smear a little oil on the O ring mounting the fuel filter vertically. This will provide a better seal from the O ring and limit the possibility of air being trapped inside and then coming out at an inopportune time. It is also better not to affix it but to leave it free to slightly move.

When running the engine at full power, check the fuel line from the pump to the engine. If there is a large quantity of air bubbles flowing with the fuel, there is probably a restriction in the fuel system or an air leak in at least one of the many fittings.

Be careful not to over-pressurize the fuel tanks and the shut off valve during refueling operations.

You want to make sure the vent is not plugged up. We are now requiring a manual shutoff valve, as an additional prevention of pumping raw fuel into the engine and to avoid a subsequent wet start.

UAT (Ultimate Air Trap)

A UAT is recommended, between the main fuel tank and the engine. KingTech highly recommends the BVM UAT or its equivalent. Always use a filter between the fuel pump and the turbine as shown in the diagram. The pump may emit small particles that can block the solenoid valve in the turbine from completely closing!

Prime the Pump and System

To prime fuel pump and fuel lines (or for fuel pump test purposes), it is necessary to open the manual fuel shutoff valve and run fuel pump manually. For this operation, use the GSU and go to TEST icon, and scroll to 6 of 9 or 6/9 to Test Pump. This test opens the fuel valve and acts as a speed control for running the pump.

Tap on the #1 ON button to begin (at this time the pump will run at very low voltage) then you might want to increase pump power by tapping on the same button until desired pump speed reached (more tap more power) pump will continue running at the last tapped power, then tap #2 button to turn it off.

Extremely Important:

Pump Test allows the fuel pump to operate without the turbine running. However, if the fuel feed line is not removed from the turbine during this procedure; it will become flooded with fuel. When this occurs, the next turbine start can become highly combustible!

Before activating the pump test mode, ALWAYS remove the fuel feed line connected to the turbine and dip the line back to your fuel can or overflow tank.

Fuel System Connection Diagram G Model

Fuel System Connection Diagram

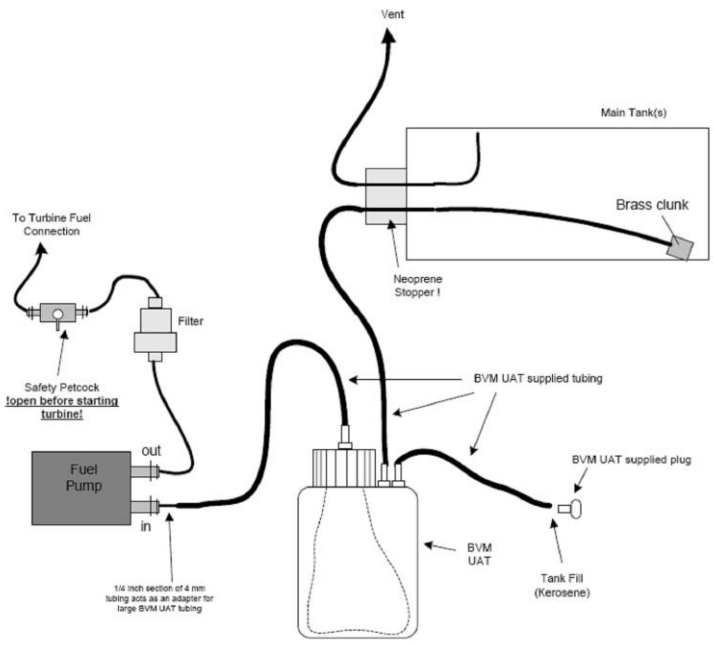

Mounting the Turbine

A two-piece, aluminum mounting bracket is included with the turbine. Place the bracket around the turbine, with the glow plug situated within the slot of the smaller bracket piece. This will help stabilize the engine along the thrust axis. The glow plug must be in the vertical position, when mounted in your model (+/- 75° of engine rotation, from the glow plug at top dead center, is the allowable deviation). Secure the engine, using four metric mounting screws and lock washers that are provided with the bracket.

Other Notes on Turbine Installation

When the turbine is mounted in models with the air intake at the bottom, for example an F-16, care should be taken to prevent foreign object damage of the compressor blades.

This can be accomplished by using a strainer screen at the inlet. The screen mesh should be about 0.06 inches in width.

KingTech also offers an FOD screen as an optional accessory and it is highly recommended to protect your investment.

Installing the Fuel Pump

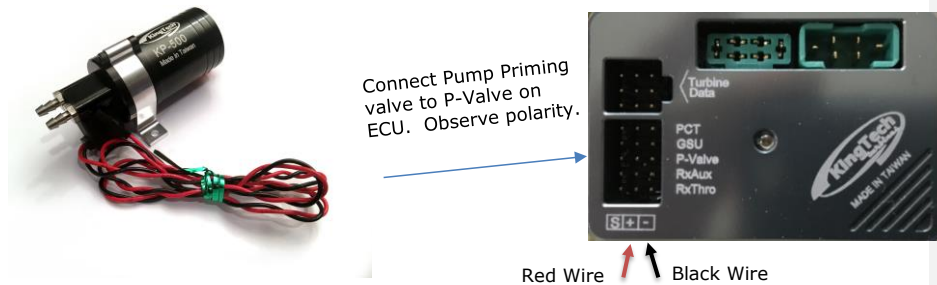

Connect pump MPX power cable from ECU to pump and from ECU to ECU battery.

Note: THE MPX CONNECTOR THAT ATTACHES TO THE PUMP HAS ONLY 2 WIRES. THE MPX CONNECTOR WITH 4 WIRES ATTACHES TO THE ECU.

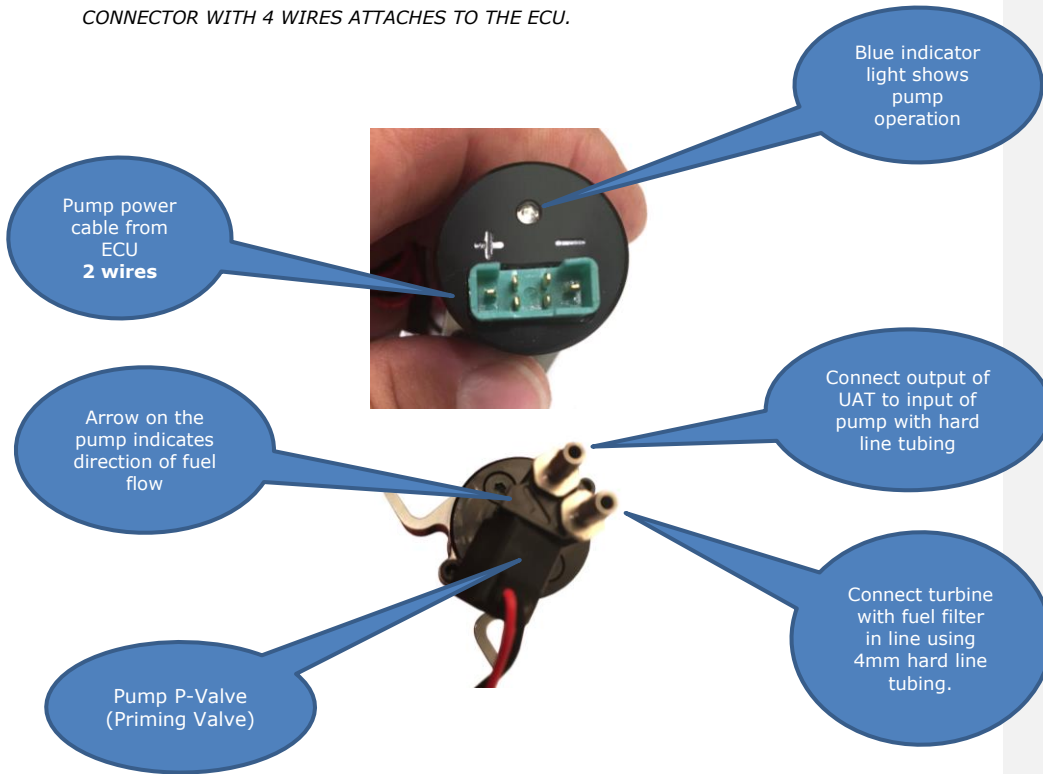

Connections at the Turbine & ECU (G Models)

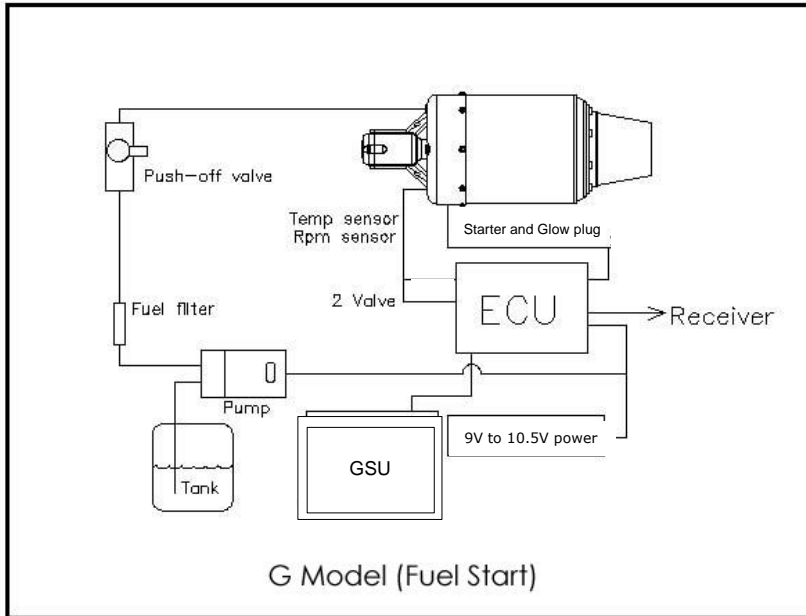

New Data Connector at Turbine

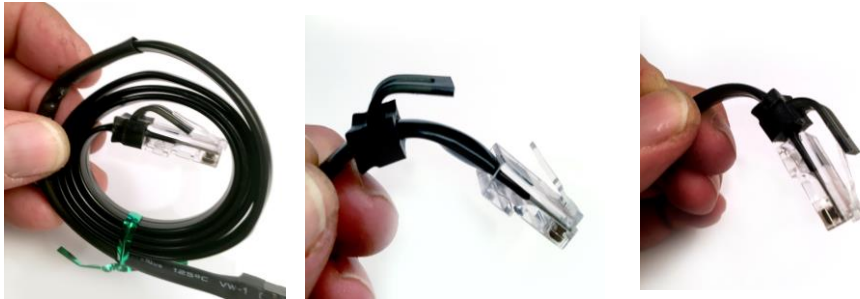

The data connector at the turbine end has a new safety latch and removal assisting mechanism. This assist device pictured above on the left if placed under the plastic tab when attached to the turbine acts as a locking mechanism. The center picture above shows the latch in the retracted position. The picture on the right shows the device above the tab on the data connector in a position to assist with removal of the data cable from the turbine.

ECU Connections

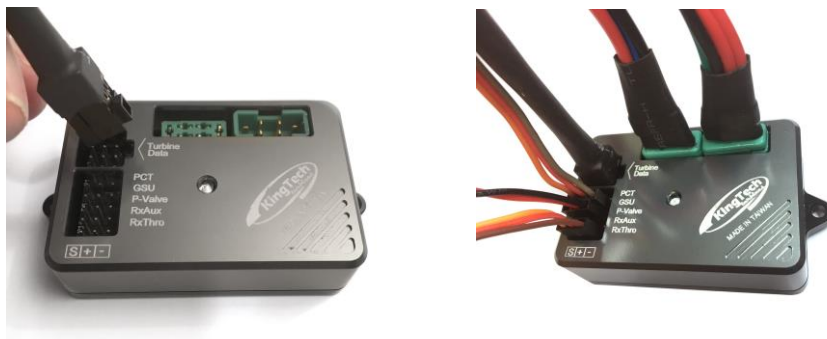

The picture above shows the new single data cable with a keyed connector which prevents it from being inserted into the ECU incorrectly. The picture on the right shows connection of all cables on the ECU from the turbine, receiver, pump and GSU.

ECU Battery *(not included)*

Electrical power for all electrical components for our F/G series turbine (starter / glow plug / ECU / fuel pump / fuel and gas valves) will require a 3S LiFe pack or 7C NiMh from 2000mah to 5000mah ECU battery. The amount of battery capacity used per flight is approximately 300-350 mah. This includes starting and cool down. The ECU battery must not be used over 80% of its capacity, or it must be recharged.

Charging the Battery - Do not charge the battery with a charger using negative discharge pulses when connected to the ECU. This will destroy the electronics of the ECU. You must disconnect the battery from the ECU and charge it directly.

Also, we recommend you reset the battery used value to zero using the GSU. Go to the menu item "Info", "Battery" then press the "+" button after each completed charge. This will clear the cumulatively monitor mAh used. Again, make sure you stop flying and starting charging if it the value is near 20% of the capacity.

Note: If your turbine does not start on the first flight of the day after fully charging your ECU battery, check the GSU for an error message. 3S LiFe packs peak at 10.8V when fully charged. This will cause an error message on the GSU "Voltage Overload". To resolve this issue, with Trim Down, stick up to actuate starter motor for 5 seconds. This will bleed the voltage down just enough to get it closer to nominal for normal operation.

Description of the ECU

The ECU is a system for the control of a model gas turbine engine. Its main function is to control and regulate the fuel pump, providing to the turbine engine the necessary amount of fuel for safe and controlled operation, and to operate the ancillary devices for starting. The ECU measures the exhaust gas temperature, the relative position of the throttle stick and the rotor speed. It monitors all of the controls necessary to make sure that the engine stays between the user defined parameters of operations, also providing failsafe shutdown of the engine when it has detected any important anomaly. In order to make this assessment, the ECU has a rpm sensor, a thermocouple input, a throttle servo input, power connections for the fuel pump, fuel pump primer valve, starter, glow plug, fuel and gas valves and the battery and a data port to program and read the data in real-time from the GSU or a PC. The measurements made by the ECU are:

- Temperature of the exhaust gas
- Battery voltage
- Battery current
- Width of the throttle pulses from the radio transmitter
- Engine rotor RPM
- Engine run time.
- External analog signal (airspeed sensor)

Features:

- RPM input: Magnetic sensor up to 250.000 R.P.M.
- Temperature range up to 1000°C using a "K" type thermocouple
- PWM control of 8192 levels for pump, glow plug and starter motor.
- Adjustable power for the starter motor
- Build-in electronic brake for the starter motor to help the clutch to disengage.
- Blown glow-plug detector
- Adjustable glow-plug power

- Glow-plug temperature independent of the battery voltage
- Elapsed engine run timers
- RS232 or USB interface to PC, cable must be purchased separately.
- Black box function. Record the engine measures each 0.5sec up to 52 minutes.
- Radio link error counter
- Battery usage counter in mA/h, (reset this value on a freshly charged pack)
- Test functions for all connected devices.
- P-Valve, pump priming - in a start sequence, during burner on, the ECU will command fuel pump to conduct self priming, by closing the integrated solenoid valve on our new fuel pump to engage a self- looping pump run
- Temperature probe failsafe with allow the turbine to continue to run even when the temperature probe is no longer working
- Auto-restart modes including automatic restart and glider modes.
- Fuel and Gas valve error detection.
-
- Turbine Cooldown and auto-shut off with RX power turned off.



Setting up the ECU

All the programming and measurements are done through the GSU, Ground Support Unit. The GSU is a Handheld Data Terminal featuring a bright touch screen display. When you first connect the GSU to the ECU via the connection labeled GSU on the ECU or turn on power to your aircraft the logo screen appears briefly.



Next a **Dashboard** screen appears displaying a host of information..

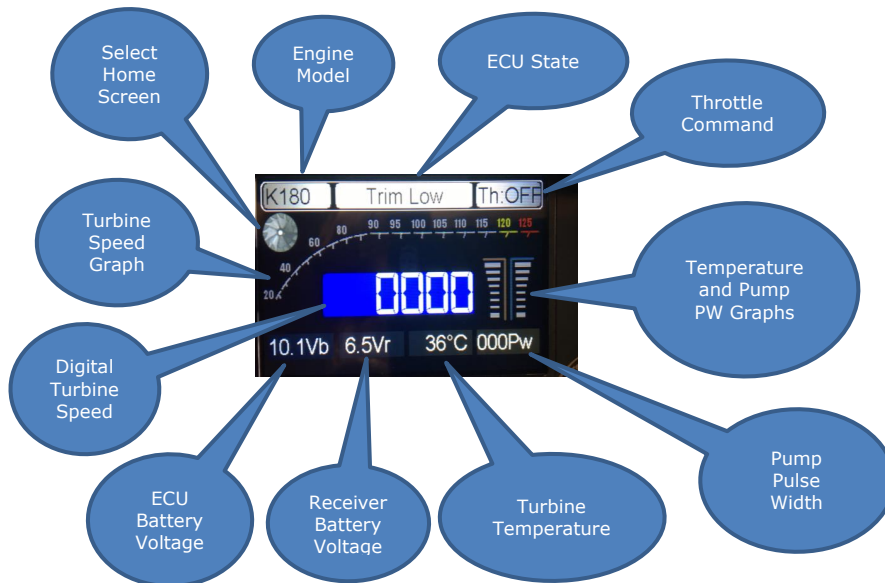

Next touch anywhere on this screen to select the Home Screen of functions available on the ECU.



The **Home Screen** for the ECU is displayed. All the functions available can be displayed by using the scroll bar on the right side of this screen

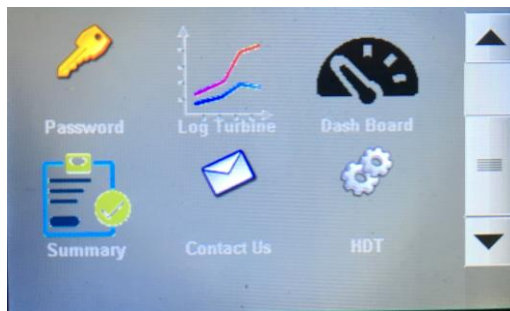

For now, touch the Radio button, the icon looks like a transmitter.
The following screen appears.

 A screenshot of the 'Transmitter 1/6' screen. The title bar says 'Transmitter 1/6' with an 'X' icon. The main display shows 'Rx: 0877uS 000%' and 'Idle: 012%'. Below the display are four buttons: '<1> Sub-', '<2> Add+', '<3> Prv. <<', and '>> <4> Next'. Four blue callout bubbles point to these elements:

- 'Menu Title Page 1 of 6' points to the title bar.
- 'Throttle pulse width' points to the 'Rx: 0877uS 000%' value.
- 'Exit Menu to previous screen' points to the 'X' icon.
- 'Relative stick position' points to the '<2> Add+' button.

Pressing the "Next" button enters the RC Learn menu.

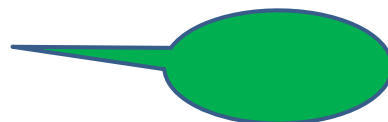

Learn R/C – Teach the ECU Your Radio System

Learn RC, follow below procedures to ensure learning RC for proper failsafe.

1) For JR [and](#) Spektrum Compatible [and](#) Jeti, Power on [the](#) transmitter and make sure [the](#) throttle reversing is [set to](#) normal, travel 100% and put Stick Down, Trim Down, then turn off transmitter.

1a) For Futaba and compatible, do the above except activate [the](#) reversing on [the](#) throttle channel

2) Bind [the transmitter](#) to [the receiver](#) with stick down trim down

3) Touch anywhere on the Dashboard for the GSU Home Screen.



5) Touch "Radio" on the Home Screen

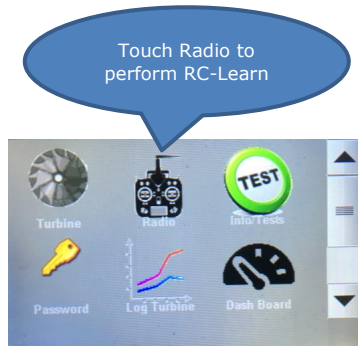

6) To Start the RC-Learn process press <4> Next.



Note: The correct reading of throttle % by the ECU can be verified on this screen, percentage of the throttle position is shown on, 0% in the position of engine stop (trim and stick down), 100% with stick/trim full up and between 10% and 30% at idle, (stick up trim down).

7) Press <2> to enter the RC-Learn function.

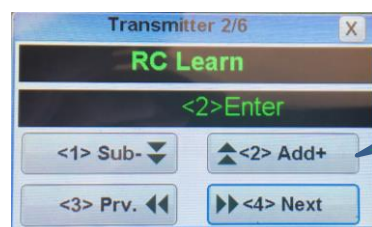

8) [Place the Stick Up](#) and [the Trim Up](#) on [the transmitter](#) and press <2> [on the GSU](#)



Press <2> to Save and continue

9) [Place the Stick Down](#) and [the Trim Down](#) on [transmitter](#) and Press <2> [on the GSU](#)



Press <2> to Save and continue

10) [Place the Stick Down](#) and [the Trim Up](#) on [the transmitter Tx](#) and Press <2> [on the GSU](#)



Press <2> to Save and continue

11) Use <4> [on the GSU](#) to scroll to "HALF EXPO", default and recommended curve see Throttle Curves for additional information.



This now completes your radio setup. **Re-learning RC is also useful if you are experiencing high idle due to a broken-in pump motor, typically about 1 to 2 hours from brand new.**

On your first start after RC learned: Be patient until ECU stabilizes idling RPM, this may take up to 1 minute or so, subsequently hold on tight to your airplane and apply full throttle, and again let the ECU to stabilize its peak RPM, then back down to idle to verify, do this a couple more times and you are ready to go.

Note: Error "Cooling Down" message - Anytime you have a cool down message after you completed the above steps for Learn RC, you have a connection error, most likely your throttle cable is plugged in incorrectly, please check polarity and/or correct slot.

Setting the Restart Function

By default the Restart function for the Turbine is set to OFF. Before you enable the Restart function it is important to understand the drawbacks, and limitations and the limited advantages of it's use. The advantage of automatic restart is that it will restart the turbine whenever a momentary interruption in fuel supply occurs. Logically, if the fuel supply is unreliable, the likelihood that it will continue to be unreliable is great. Therefore, restarting the turbine in all likelihood will result in another flameout. The liability that exists in this situation is that if the failure results in a crash, a fire is much more likely to occur when the restart function is turned on. It takes approximately 15 seconds for the Restart function to restore turbine power. In many aircraft where heavy wing loading exists, this is not enough time for the aircraft to glide without impacting the ground before the restart would be effective in restoring power.

Disclaimer

By turning on the Restart function, the user agrees the he/she fully understands the workings of this function and the user assumes all responsibility for any negative outcomes resulting from the Restart function being enabled.

To set the restart function touch anywhere on the Dashboard.

The restart function has three settings, Off, Restart and Glider. If the setting is set to Off then no restart is attempted. If the Restart Mode is set to Restart, the ECU will attempt an automatic restart in event of a temporary interruption of the fuel supply. In Glider mode the user may shut down the turbine in the air and then later restart it providing the turbine temperature drops below 150C.

Touch the Dashboard to go to Home Screen

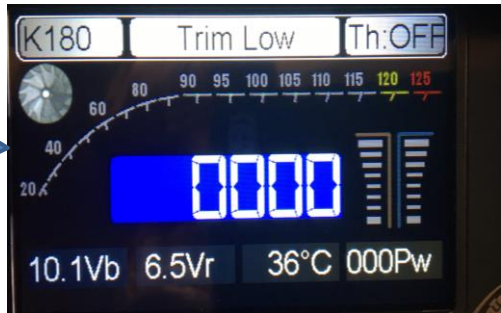

Touch the Turbine Wheel for the Turbine Menu

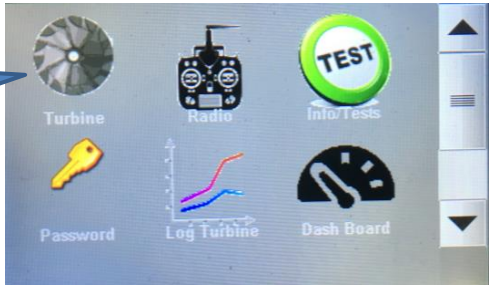

Press <3> for the restart menu.

Press <3> for ReStart



To turn the restart mode on Press <2>. Press <3> to go to previous menu. To exit and return to previous menu press <4>

The screenshot shows a menu titled "ReStart Menu 1/1" with a close button (X) in the top right corner. The main display area shows "ReStart MODE" in green on a black background, followed by "RESTART ON" in green on a black background. Below the display are four buttons: "<1> Sub-" with a downward arrow, "▲<2> Add+" with an upward arrow, "<3> Prv. ◀◀", and "▶▶<4> Next".

Callouts:

- Red circle: Press <1> to turn Restart Mode Off
- Green circle: Press <2> to turn Restart Mode On.
- Blue circle: Press <4> to return to previous menu

To turn Glider mode on press <2> again. To exit and return to previous menu Press <4>

The screenshot shows the same menu titled "ReStart Menu 1/1" with a close button (X) in the top right corner. The main display area shows "ReStart MODE" in green on a black background, followed by "GLIDER" in green on a black background. Below the display are four buttons: "<1> Sub-" with a downward arrow, "▲<2> Add+" with an upward arrow, "<3> Prv. ◀◀", and "▶▶<4> Next".

Callouts:

- Red circle: Press <1> to turn Glider Mode Off
- Green circle: Press <2> to turn Restart Mode On.
- Blue circle: Press <4> to return to previous menu

Throttle Curves

Jet engines develop the thrust exponentially, thus half of the RPM is only approximately 1/4 of the thrust. On small engines with a high idle to full power rpm ratio, or in a high drag/low power plane, often only the last 1/3 of the throttle stick produces significant thrust. The low half of the stick travel is not used. Although current digital Transmitters can modify the throttle curve to suit the requirement of the model, the Kingtech ECU can simplify the installation by adjusting to three different throttle curves as follows:

FULL EXPO: Mean linear RPM, it is the default setting and the mode used for all previous software versions. Thrust develops exponentially, and it is the recommended curve for big engines or/and high thrust/weight ratio planes, as it ease the control in low power used during taxi.

LINEAR: Mean that the thrust develop linearly with the throttle setting, has more resolution at lower half of the throttle stick.

HALF EXPO: An intermediate setting between the previous two modes. This is the KingTech factory setting and we are sure you will find this setting to be the most suitable.

MODE	Stick position					% of total thrust
	0% (Idle)	25%	50%	75%	100%	
FULL EXPO	Idle thrust	6%	25%	56%	100%	
HALF EXPO	Idle thrust	16%	38%	66%	100%	
LINEAR	Idle thrust	25%	50%	75%	100%	

Test/Info Functions

The ECU provides testing functions to the starter motor, glow or burner plug, pump and both solenoid valves. These test screens are only available when the ECU is on the "Trim Low" status, that is to say, recently powered up and receiving a STOP signal from the TX. Pressing the <1> button will energize the selected device and pressing <2> will shut it down. Special care should be taken when testing the pump, as it is possible that fuel can be pumped into the engine, flooding it, and causing a hot start on next startup. Testing the pump works differently than Xicoy ECUs in that the <1> on function must be pressed repeatedly to increase pump flow. Prior models increased pump flow during test with only a single press of the button.

***Some LiFe chargers is capable to peak a 3S pack over 10.7V, the ECU might display "Over Voltage" and will not engage engine start mode. Please go back to Description of the ECU to bleed off the peaked voltage.**

To initiate the test functions press the turbine wheel from the **Dashboard**.



Home Screen: Press "Test" to initiate the test functions.



Press Test to initiate test functions

Test/Info page 1 displays Turbine Total Time in minutes, last Cycle time in seconds and number of cycles. *Note: These numbers are reset to 0 upon overhaul. (Interval 25 hours)*

Displays page number and total pages



Press X to exit to Home Screen

Press <4> to proceed to next screen

Test/Info page 2 displays condition of last shutdown with Temperature, RPM and Pw.

Press <3> for previous screen



Press X to exit to Home Screen

Press <4> for next screen

Test/Info page 3 displays ECU Burn date and version information.

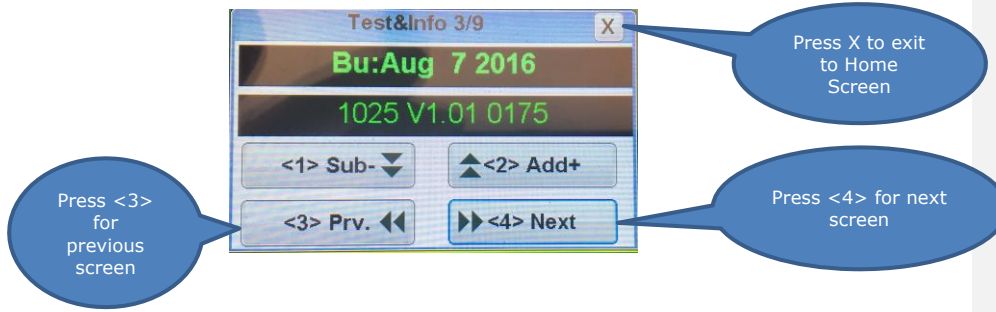

Test/Info page 4 is for testing Starter

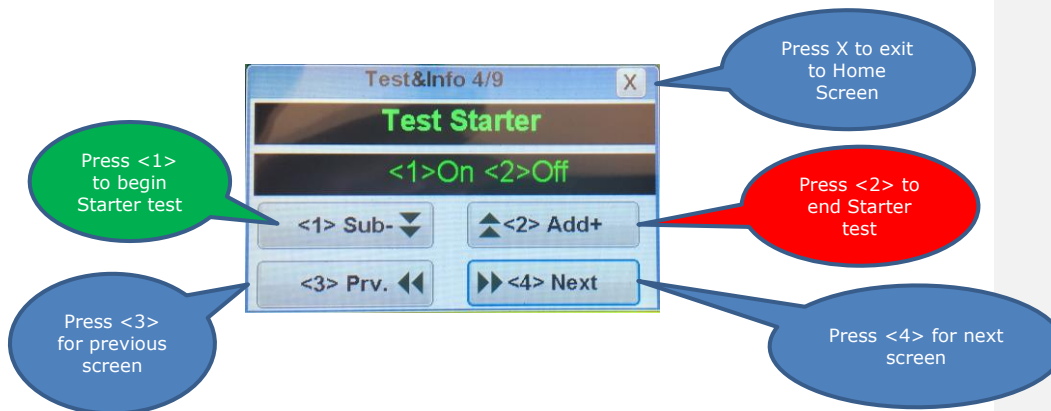

Test/Info page 5 is for testing the Glow Plug.

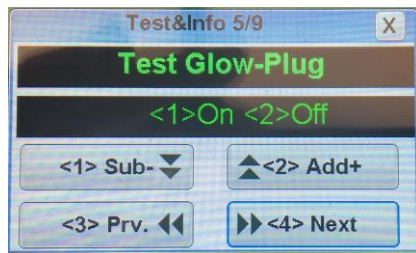

Test/Info page 6 is for testing Fuel Pump.

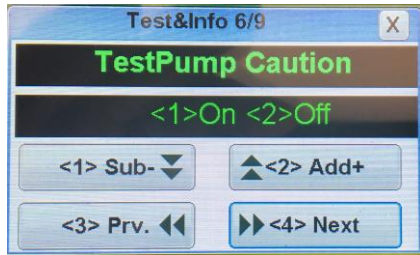

Test/Info page 7 is for testing the Gas Valve.

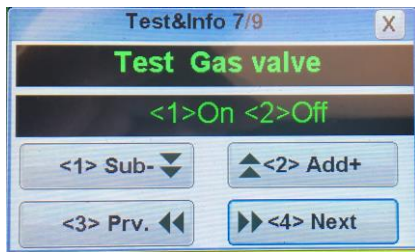

Test/Info page 8 is for testing the Fuel Valve



Test/Info page 9 is used for priming the turbine.



Turbine Starting and Running

Always set-up and confirm the operation of your Auto-start installation on the test-stand, before installing into your model. This will help you to familiarize all components associated and the characteristics of different stages of turbine engine starting.

The present version of auto start uses only one channel for the entire engine functions: To trigger the auto start cycle, the process is as follows:

- The user raises the trim. "Ready" will appear on the GSU screen. The trim and stick should be where the engine is supposedly to be to idle once running. If the trim is on "stop" position, "Trim low" will be read on the GSU.

If throttle value is higher than idle, "StickLo!" will be read.

- When "Ready" is displayed, the user should cycle the stick to beyond ½ throttle and back to idle in order to initiate the start sequence. *** For F & G models, do not be alarmed by the starter motor engaging the rotor if you place the throttle on full, this briefly actuates manual cool down***

Stage 1

- The burner plug is powered and checked. Once hot, the starter is engaged at reduced power (soft start). If the glow test fail, a "Glow Bad" message is displayed, and if the starter fails to arrive a minimum RPM in 2 seconds, a "start bad" message is issued, and the auto start function aborted.

- **Ignition** – (Ambient to plus 4C) When the rotor arrives at more than the "ignition max rpm" programmed parameter the starter is disconnected, the ignition fuel is being introduced; you could recognize this by the clicking sound of burner fuel solenoid and the pulsating of fuel pump. Once this fuel delivery is engaged, you would want to hear a very positive "pffffff" ignition.

- **Preheat** – (up to 72 C) Once the temperature climbs for 2 to 4 degrees from ambient, Preheat stage commences, flame is something you do not want at this stage. If flame is present, abort (trim down) you could either reduce Preheat fuel or increase preheat RPM.

What you want to see is a steady climb of temperature up to 72C.

Stage 2

• **Switch Over** – (up to 200 to 300 C) This is the stage that the main fuel also opens and a slight yellow to bluish flame is expected, while starter motor drives the rotor even faster in preparation for fuel ramp.

Stage 3

• **Fuel Ramp** - Some popping and some flashes of yellowing blue flame is expected. At this stage, the burner valve is closing while the pump and start motor drive the engine up to idle temperature and RPM, once Running, your transmitter takes over the engine.

- Watch out for temperature hanging at a certain stage, primarily Ignition and/or Preheat. This will potentially accumulate fuel and an undesirable wet-start may occur.
- It'd be a good practice to extend your GSU to be viewed in-line with the tail cone to have a sighting of possible fuel dripping or flame.

NOTE: Do not confuse the auto-start function described above with the auto-restart function previously discussed under Setting the Restart Function.

Before you call tech support on start-up related issues, please have enough above information to facilitate an effective support.

Turbine Stopping and Cooling

The user can finish the sequence at any moment, simply setting the trim to "off" position. If the engine was on "running" phase (above idle rpm), a cooling sequence will be triggered, cycling the starter motor until the EGT is below the minimum programmed temperature. This cooling sequence will be aborted if the trim is raised again.

- If the engine is hot (EGT higher than the minimum temperature) at the moment that the user triggers the auto start cycle, then the ECU will begin a cooling cycle until the temperature is below 100C.

You may turn off power to the receiver at any time after engine shutdown and the ECU will continue to cool the turbine. When the cooling is below 100C the ECU will shut down. This is a new feature of the KingTech Series 2 ECU.

Manual cool down:

In the event if engine does not go into the cool down mode after the turbine shuts down or flames-out, the user can lower the trim, and advance throttle stick to trigger cooling from the starter. Make sure you simulate the auto cooling sequence and monitor the real time temperature and do not leave motor running for longer than a couple of seconds.

Another option is to unplug reconnect power to ECU. This power cycle will enable ECU to recognize that the engine temperature is still higher than normal, and should engage auto cool down.

Run Menu

To access the Run menu touch anywhere on the **Dashboard**.



Touch the Turbine on the Home Screen to select the Function Menu.

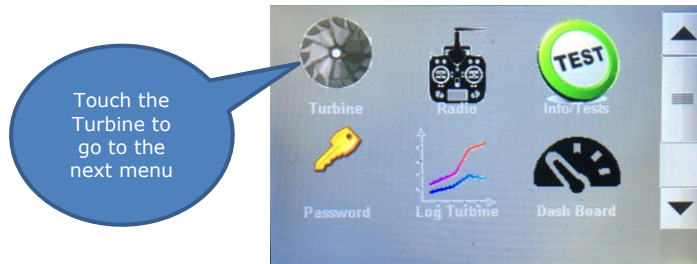

On the function selection screen press <1> Run



Under this submenu, the parameters used for the engine during normal run can be modified. Note: Some of these menu parameters cannot be changed by user. It was factory set for best operation and to protect turbine. **Please do not change these values set by factory. This may void your warranty!**

Full power speed: On this screen you can set the RPM that the engine will run at 100% throttle. If the engine manufacturer has set a maximum limit, you will only be able to reduce the max RPM.

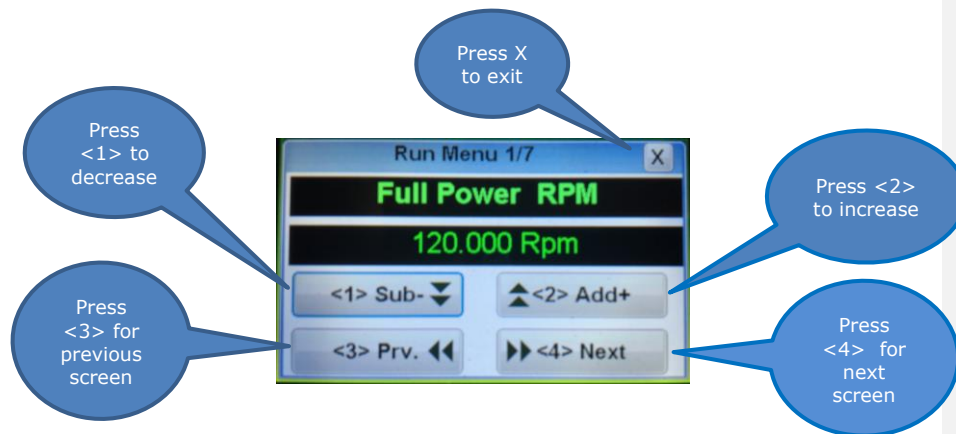

Idle speed: Set the RPM that the engine will run when the ECU receive IDLE Command. While the engine is running, the ECU will adjust the rotor speed accordingly the throttle position in a closed loop system. (For rough idle, please refer to TROUBLESHOOT towards the end of this manual)



Maximum temperature: Set the maximum temperature that the engine is allowed to run. The ECU will reduce the acceleration rate if the EGT approaches to maximum and will reduce the pump power if necessary to keep the temperature below the maximum, but it don't will cut the engine if the temperature is too high, it will try always to keep the engine running by reducing the fuel flow. 850 DEG C

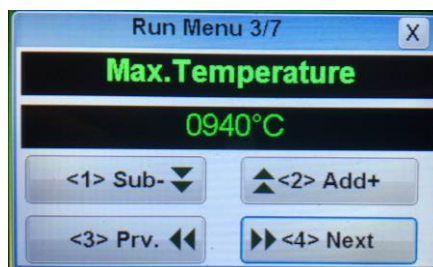

Acceleration delay: Set the acceleration time on the engine. Higher the values, slower the acceleration. The real acceleration is calculated using a complex algorithm that take in to account this value, temperature, current RPM, commanded RPM, and the tendency of EGT and RPM.



Deceleration delay: Similar to the acceleration, but used during throttle down. Higher values mean slower deceleration.



Stability delay: When the engine is running at constant throttle setting, the ECU is adjusting continuously the pump power so that the rotor RPM mach exactly with the throttle signal. The speed of which the ECU adjusts the pump power as set by this parameter. A value of 100 usually is the best for all engines. A too low of a value can cause instability on the RPM.



Pump Limit: The ECU can give to the pump the full battery voltage, but in most cases the voltage needed for the pump is only a fraction of the full battery voltage. Limiting the pump give a much smoother control of the engine and prevents that the pump could receive excessive voltage in the case of a problem in the fuel circuit, a clogged filter for example. This excessive power will cause a high pressure on the circuit that can cause leaks or blown tubes. Modifying this parameter is similar to reducing the battery voltage, so the accel and decel times will be modified. The most ideal is to have the limit set at the lowest and still be able to reach full max RPM, run the engine, check and annotate the Pw of the pump displayed on the first screen when the engine is running at full power and then use this value as pump limit, increasing it in a 15%-20% to give a bit of margin for weak batteries and pump wear. Once the new value set, adjust the accel and decel delays for best engine handling.

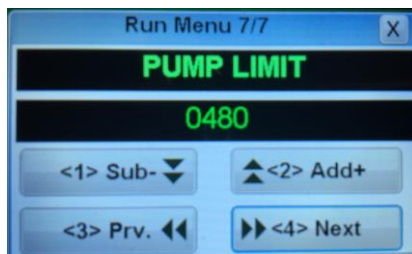

Start Menu

Startup parameters are set at the factory and are fine tuned during run testing. No two motors are exactly the same, so comparison with another motor of the same type may not yield the same result or value. Do NOT attempt to change parameters unless specifically instructed to do so by KingTech technicians. Doing so on your own may void the turbine warranty.

To access the Start menu touch anywhere on the **Dashboard**.



Touch the Turbine on the Home Screen to select the Function Menu.

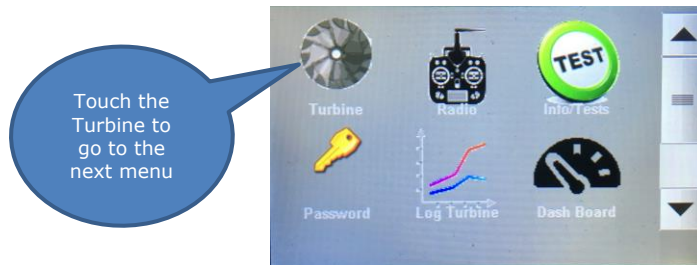

On the function selection screen press <2> start

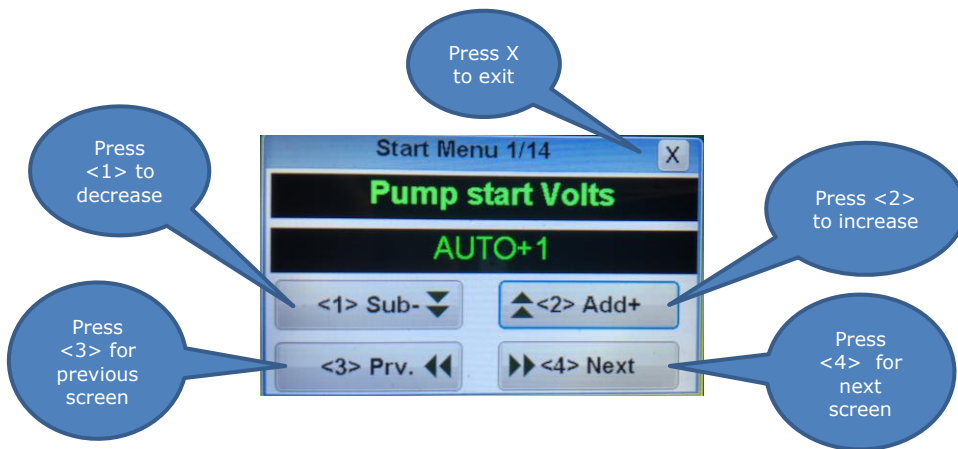

Pump start Value: Sets the power of the pump when it is started at the beginning of the fuel ramp.

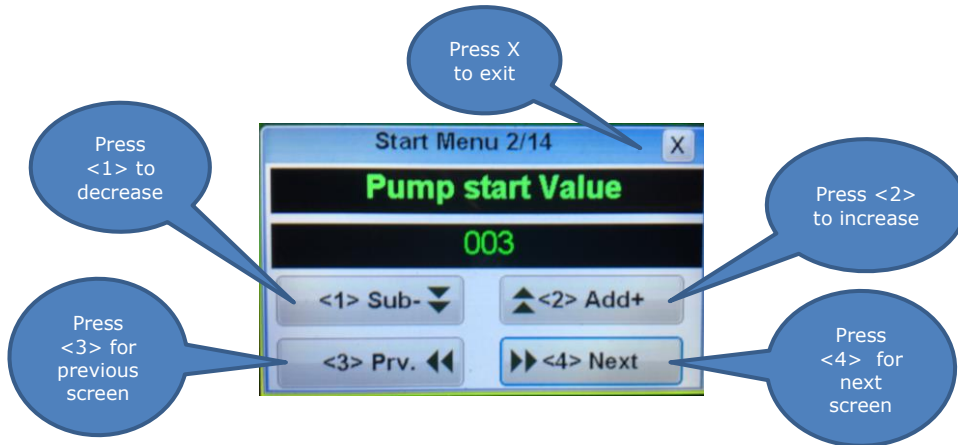

Pump Pw Ignition (in thousands): Sets the power of the pump. This adjust the amount of fuel sent to the burner during the ignition phase of startup.

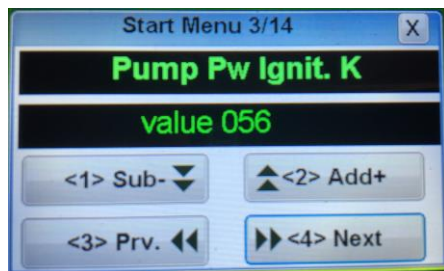

Ignition RPM: Sets the rpm where the starter will be switch off during ignition



Stage 1 RPM: The RPM that triggers stage 1 of startup.



Stage 3 RPM: The RPM that triggers stage 3 of startup.



Starter power at Ignition: The power sent to the starter motor controlling the amount of air injected into the burner can at the Ignition phase.



Stage 1 Starter Power: The power sent to the starter motor controlling the amount of air injected into the burner can during the Stage 1.



RPM 100% starter power: The resulting RPM value that is considered 100% maximum starter power.



Engine Minimum Flow in %: The percentage of time the main fuel valve is open (pulsed) during the switchover phase of startup.



Stage 1 fuel duty: The percentage of total fuel applied during Stage 1 of startup.

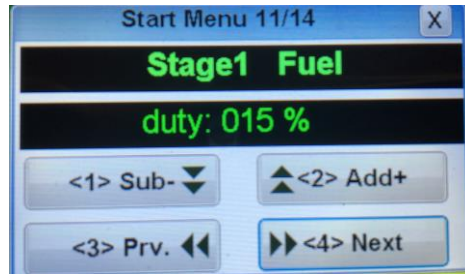

Stage 1 EGT: Temperature in Celsius.



RPM OFF Starter: The RPM at which the electric starter motor is disengaged.



RPM to reconnect: The RPM at which to re-power the starter motor if the turbine RPM falls below this value during startup.



Summary

The Summary is a listing of operating data collected on the last four turbine runs stored in the KingTech ECU and displayed on the GSU screen.

To access the Summary touch anywhere on the **Dashboard**.



On the Home Screen, touch the Turbine Log to display one of the last four turbine runs or "Rounds".

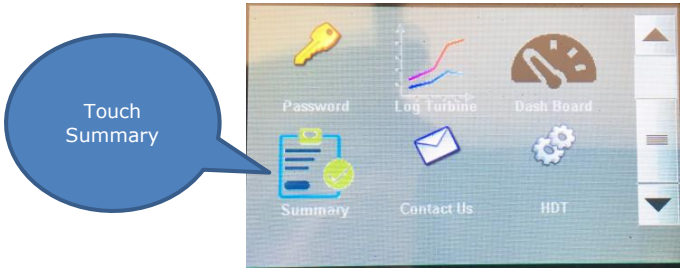

If Summary is not displayed, use the scroll bar on the right side of Home Screen to display Summary.

Next the GSU will read the logs from the ECU. Depending on the amount of data this may take a minute or two. To cancel this function and return to the Home Screen touch the "Cancel" button.

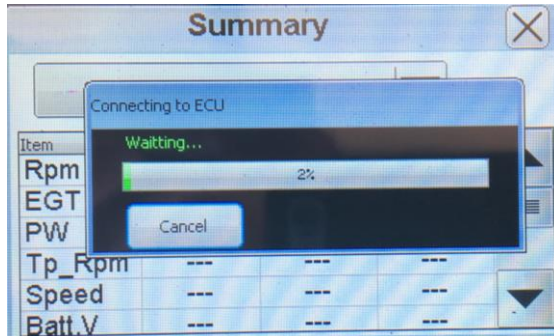

To change which of the last four rounds is displayed, use the drop down list.

The image shows a screenshot of the "Summary" screen. At the top, it says "Round 12" next to a dropdown arrow. Below this is a table with the following data:

Item	Max	Mean	Min
Rpm	34	32	32
EGT	432	420	416
PW	46	45	45
Tp_Rpm	0	0	0
Speed	0	0	0
Batt.V	9.90	9.89	9.80

Callout 1 (top): To change which of the last four rounds is displayed, use the drop down list.

Callout 2 (right): Scroll bar up or down to show all data

To display all of the information you will need to use the scroll bar on the right side of the screen

This information displayed is the Maximum, Mean, and Minimum values for each of the following data items:

Turbine RPM

EGT – Exhaust Gas Temperature

PW Pump Pulse Width

Tp_Rpm (Turbo prop Shaft Rpm)

Speed (Air Speed from accessory device)

Battery V. : ECU battery voltage

RX. V : Receiver battery voltage

AMP: ECU current. Engine running only

AbNor: Diagnostic Codes

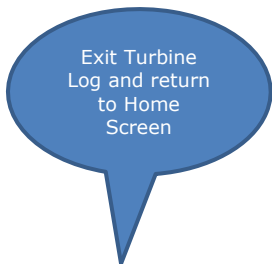

Item	Max	Mean	Min
Tp_Rpm	0	0	0
Speed	0	0	0
Batt.V	9.95	9.94	9.70
Rx.V	6.50	6.43	6.20
Amp	2.44	0.59	0.49
AbNor	45	72	-7

This function is a subset of data stored by the ECU. A more complete data log will be available using the PCT (PC Terminal interface) at a future date.

Turbine Log

The Turbine Log is a graphical display of Turbine Log data which scrolls across the screen in reference to lapsed time for a turbine run.

To access the Turbine Log screen, touch anywhere on the Dashboard.

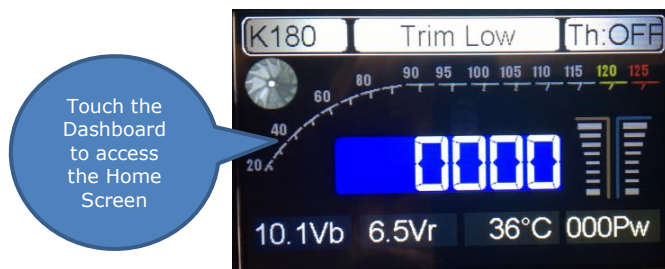

On the Home Screen, use the scroll bar to display the Turbine Log Icon.

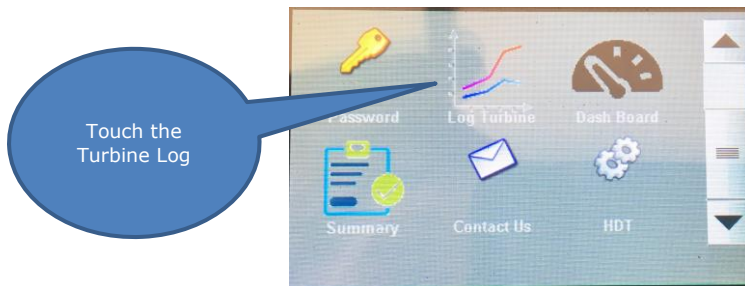

Make sure Throttle Trim is in off position to retrieve log data.

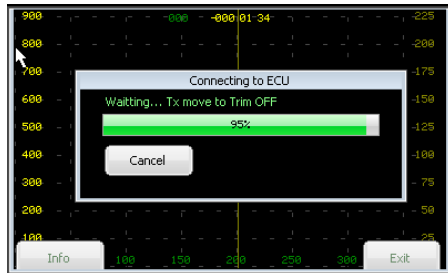

Select one of the four most recent turbine runs *(Rounds)" and touch the Download button

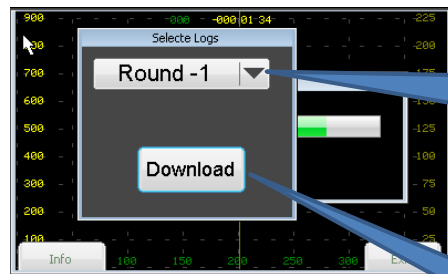

Select one of the four most recent rounds to display.

Touch Download button to start data download.

Select data to be displayed from one of four most recent turbine runs.



Wait for data to be displayed.

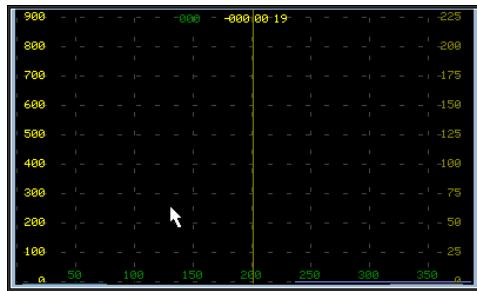

Touch the Info button for buttons to be displayed for control of displayed log data or press Exit to return to Home Screen.

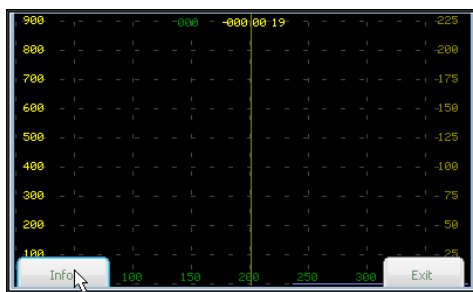

Touch the "Full Screen" button to return to display without control buttons. . The data will scroll on the screen from right to left representing a time line for the data. Press Back, Pause or Forward to control the graphic display of data. This is helpful in comparing the relationships between the various data points. Colored lines on the graph represent.

Green – RPM in thousands

Orange – Pump PW (Pulse Width)

Red – Temperature Celsius

Violet – Throttle %

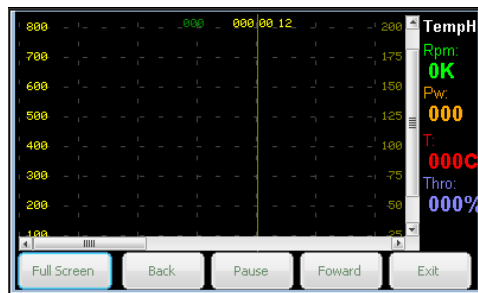

Press Exit to return to previous screen.Home Screen.

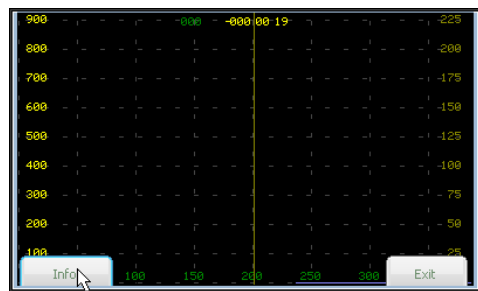

Press Exit to return to Home Screen.

List of ECU Status Message Codes

Here is a list of possible messages shown on the data terminal screen and their meaning.

TrimLow: Indicates that the signal received from the transmitter corresponds to the lowered trim, that is to say, engine OFF.

Ready: Indicates that the engine is ready for starting, and that the transmitter signal corresponds to IDLE, (green LED lit)

StickLo!: This indicates that the throttle stick is in the IDLE position, the engine will not start with the stick in this position.

Glow Test: Verifying of glow plug

StartOn: Test of the starter

Ignition: Gas ignition phase.

Preheat: Phase of heating of the combustion chamber after detecting gas ignition.

FuelRamp: Phase of fuel acceleration until IDLE IS reached.

Running: Engine working correctly, pilot have full control of engine power.

Stop: Engine off.

Cooling: Starter operating to cool the engine. (This message would also display if ECU is connected incorrectly, most likely the throttle cable, please check all connections to and from the engine and ECU)

GlowBad: Defective or disconnected glow plug, or a short of glow system wiring.

StartBad: Defective starter, insufficient RPM reached during start.

Low RPM: Engine speed below the minimum.

HighTemp: Excessive temperature

FlameOut: Exhaust GAS Temperature below the minimum.

List of ECU Warning Message Codes:

RC SIGNAL LOST/INCORRECT: The signal received from the RX is wrong (outside calibration margin) or absent.

PUMP LIMIT REACHED: The ECU has increased the pump power up to the value set on the "Pump Limit" parameter, but the engine has not arrived to the full power. Causes could be flat battery, fuel restriction or anything that can cause a reduction in the fuel flow.

xxxx OVERLOAD: An excessive current is detected from the specified output.

|

Diagnostic Messages

During engine operation the ECU measures and stores all the engine operating parameters recorded during the last the 51 minutes of operation. These measures can be downloaded later to a PC to study the behavior of the engine in flight and to diagnose any possible problems. Also, after each cycle of operation, the ECU stores the last cause of shut down and the values of RPM, temperature and pump power at the moment of shutdown. In order to access these measures, it is necessary to reinitialize the ECU (shut down and powerup). Set the trim down (TrimLow) and push the left button on the display. The ECU will show the cause of shutdown and the measured values at the moment of shut down.

These are as follows:

Diagnosis messages:

UserOff: The engine has been shut down because it has received the shut down command from the transmitter.

FailSafe: The engine has been shut down because of loss of signal from the transmitter. Once [the ECU](#) detects a loss or invalid RC signal for over 0.5 second, it sets engine power to idle, and if after another 1.5 seconds a valid signal is still not received the engine is shut down.

LowRPM: The engine has been shut down because the RPM has dropped below a minimum. Cause could be lack of fuel, air bubbles, problem with the batteries, or defective RPM sensor.

FlameOut: The engine has been shut down because the temperature has dropped below the minimum of (100°C). (If not shut down manually, usually a thermocouple failure).

RCPwFail: Lack of power from the radio receiver

K-45G Specifications:

Diameter: 76mm (2.99")

Length: 195mm (7.68")

Weight: 700g (1 lb. 8.6 oz.)

Max. RPM: 170000

Thrust: 4.5 kg @ 15° C (9.9 lb @ 15° c)

EGT: 700°C max

Fuel consumption: 155 g / min (5.46 oz / min)

Fuel: Diesel, Jet A1, Kerosene

Lubrication: 5%

Maintenance cycle: 25 hr USD300

Recommended pump: MCT pump (no priming valve)

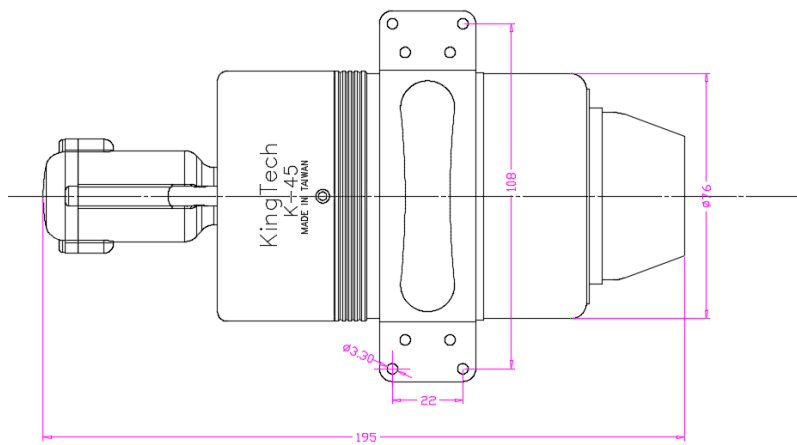

|

K-45TP Specifications:

Length: 335mm (13.19")

Weight: 1800g (3 lb. 15.5 oz.)

Maximum RPM: 170000

Power:7.3KW (8000RPM)

EGT: 700°c max (1292°f max)

Fuel consumption: 180 g / min (8.46 oz.) Fuel: Diesel, Jet A1, Kerosene

Lubrication: 5%

K-60G Specifications:

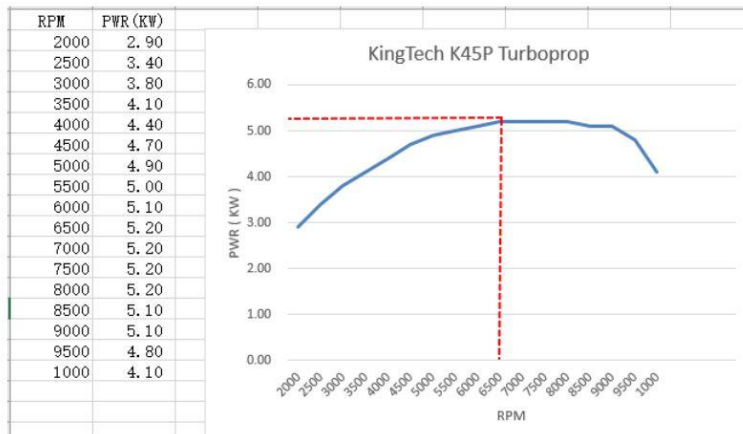
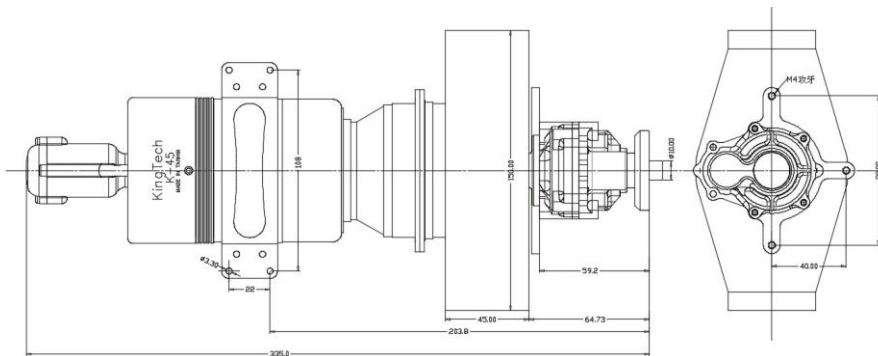

Diameter: 82mm (3.22")

Length: 228mm (8.97") - including starter

Weight: 850g (1 lb 14oz) - including starter

Maximum RPM: 162000 MAX (up to)

Thrust: 6 kg @ 15° C. (13.22 lb @ 15° C)

Idle: 50000rpm

Exhaust temperature: 700°C

Fuel consumption: 195 g / min (6.88 oz / min)

Oil: 5% (refer to Fuel and Oil/ Fuel Care Fuel and Oil/ Fuel Care for restrictions and recommendations)

Fuel: Diesel, Jet-A, Kero

Maintenance cycle: 25 hr USD300

Recommended pump: KP-500V with Priming Valve (Kingtech ECU) KP-500 (Xicoy ECU)

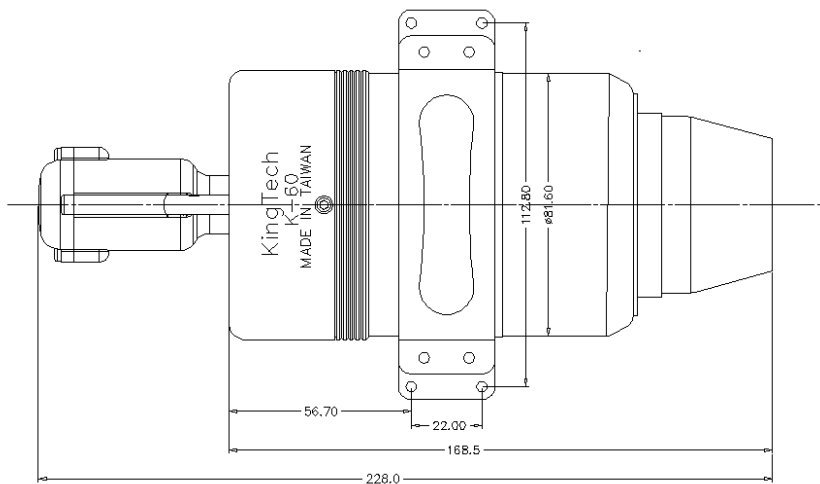

K-60TP Specifications:

Length: 385mm (15.15")

Weight: 2400g (5 lb. 4 oz.)

Maximum RPM: 160000

Power:7.3KW (7000RPM)

EGT: 700°c max (1292°f max)

Fuel consumption: 240 g / min (8.46 oz.) Fuel: Diesel, Jet A1, Kerosene

Lubrication: 5%

Recommended pump: KP-500V with Priming Valve (Kingtech ECU) KP-500 (Xicoy ECU)

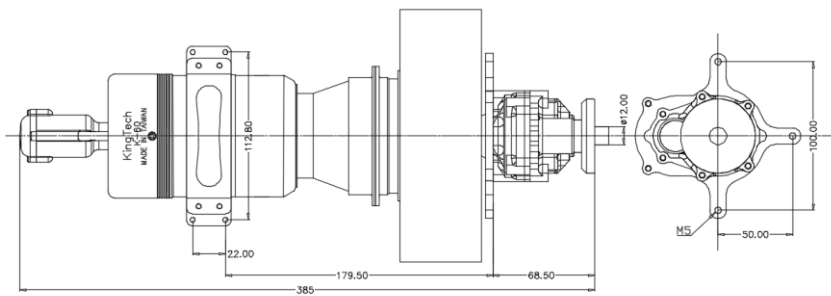

RPM	PWR (KW)
2000	3.9
2500	4.6
3000	5.2
3500	5.7
4000	6.1
4500	6.5
5000	6.8
5500	6.9
6000	6.9
6500	7.1
7000	7.3
7500	7.1
8000	7.0
8500	6.4

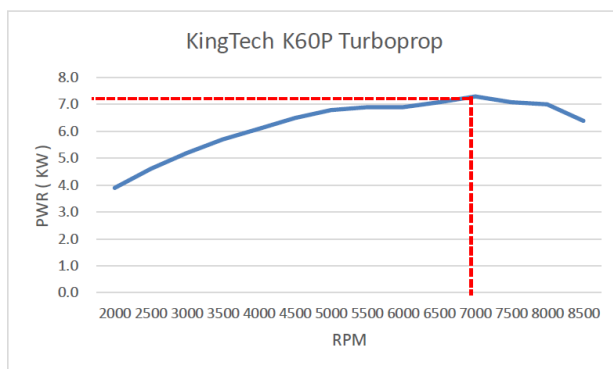

K-80G Specifications:

Diameter: 95.25mm (3-3/4")

Length: 254mm (10") - including starter

Weight: 1304 g (2 lb. 14oz.) - including starter

Maximum RPM: 145000 (up to)

Thrust: 8618 g @ 21.1° C. (19 lb. @ 70° F.)

Idle: 45000rpm

Exhaust temperature: 650°C

Fuel consumption: 239 g / min (8.46 oz / min)

Oil: 5% (refer to Fuel and Oil/ Fuel Care for restrictions and recommendations)

Fuel: Diesel, Jet-A, Kero

Maintenance cycle: 25 hrs or 30hrs with KT oil, USD300

Recommended pump: KP-500V with Priming Valve (Kingtech ECU) KP-500 (Xicoy ECU)

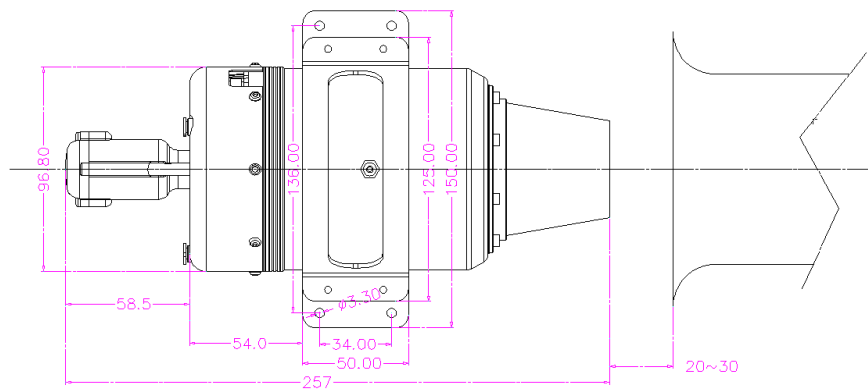

K-100G Specifications:

Diameter: 95.25mm (3-3/4")

Length: 254mm (10") - including starter

Weight: 1300 g (2 lb. 14oz.) - including starter

Maximum RPM: 142000 (up to)

Thrust: 10 KG @ 15° C. (22 lb. @59° F.)

Idle: 43000rpm, 0.85 pound

Temperature at NGV: 650° C

Fuel consumption: 350 g / min (11.84 oz / min)

Oil: 5% (refer to Fuel and Oil/ Fuel Care for restrictions and recommendations)

Fuel: Diesel, Jet-A, Kero

Maintenance cycle: 25 hr USD300

Recommended pump: KP-500V with Priming Valve (Kingtech ECU) KP-500 (Xicoy ECU)

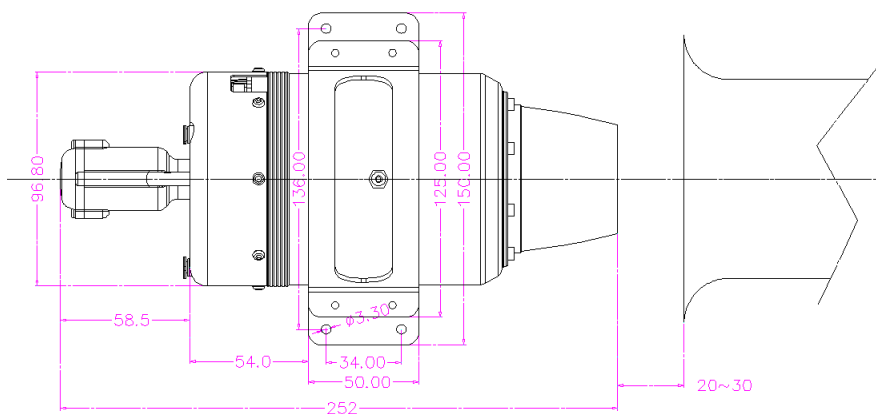

K-120G Specifications:

Diameter: 95.25mm (3.75")

Length: 254 mm (10")

Weight: 1280 g (2 lb. 14oz.)

Maximum RPM: 140000

Thrust: 12 KG @ 15° C. (27 lb. @59° F.)

EGT: 700°C max

Fuel consumption: 385 g / min (11.84 oz / min)

Fuel: Diesel, Jet A1, Kerosene

Lubrication: 5%

Maintenance cycle: 25 hr USD300

Recommended pump: KP-500V with Priming Valve (Kingtech ECU) KP-500 (Xicoy ECU)

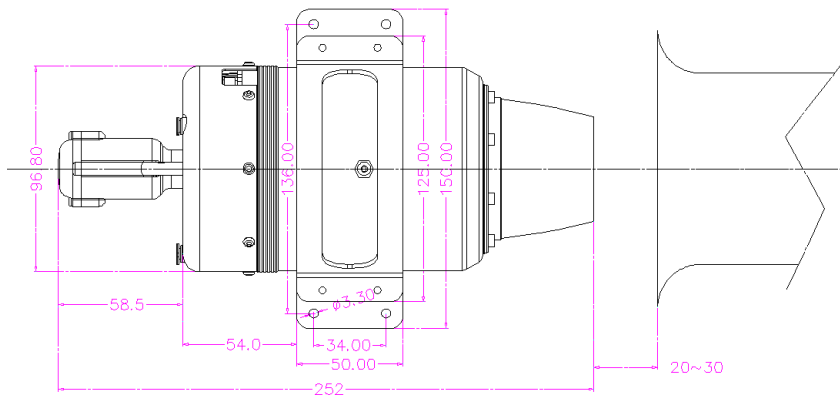

|

K-140G Specifications:

Diameter: 113mm (4-1/2")XJ0

Length: 270mm (10-1/2") - including starter

Weight: 1650 g (3lb. 10oz.)

RPM Range: 33,000 - 123,000 RPM (up to)

Thrust: 14 kg - 15° C (31 lbs @ 59° F)

Exhaust gas temp: 700°C

Fuel consumption: 400g / min—average (14.1 oz / min)

Oil: 5% (refer to Fuel and Oil/ Fuel Care for restrictions and recommendations)

Fuel: Diesel, Jet-A, Kero

Maintenance cycle: 25 hr USD300

Recommended pump: KP-600V with Priming Valve (Kingtech ECU) KP-600 (Xicoy ECU)

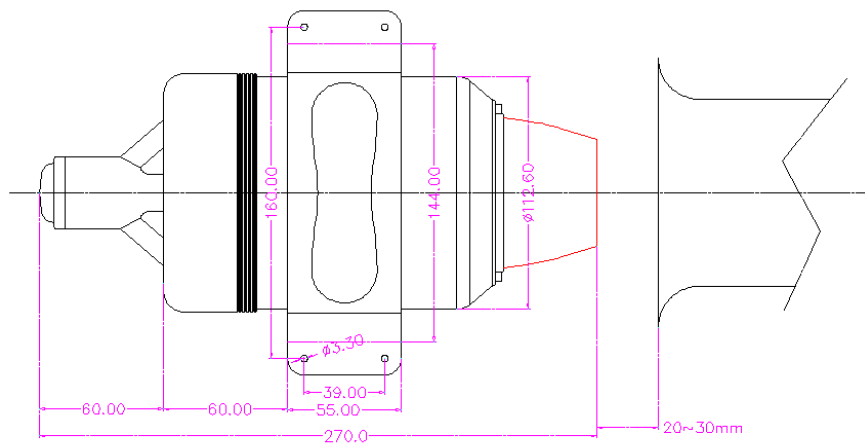

K-140G2 Specifications:

Diameter: 103mm (4.055")

Length: 260mm (10.23") - including starter

Weight: 1460 g (3lb. 5oz.)

RPM Range: 33,000 - 130,000 RPM (up to)

Thrust: 14.5 kg - 15° C (31.97 lbs @ 59° F)

Exhaust gas temp: 700°C

Fuel consumption: 400g / min—average (14.1 oz / min)

Oil: 5% (refer to Fuel and Oil/ Fuel Care for restrictions and recommendations)

Fuel: Diesel, Jet-A, Kero

Maintenance cycle: 25 hr USD300

Recommended pump: KP-600V with Priming Valve (Kingtech ECU) KP-600 (Xicoy ECU)

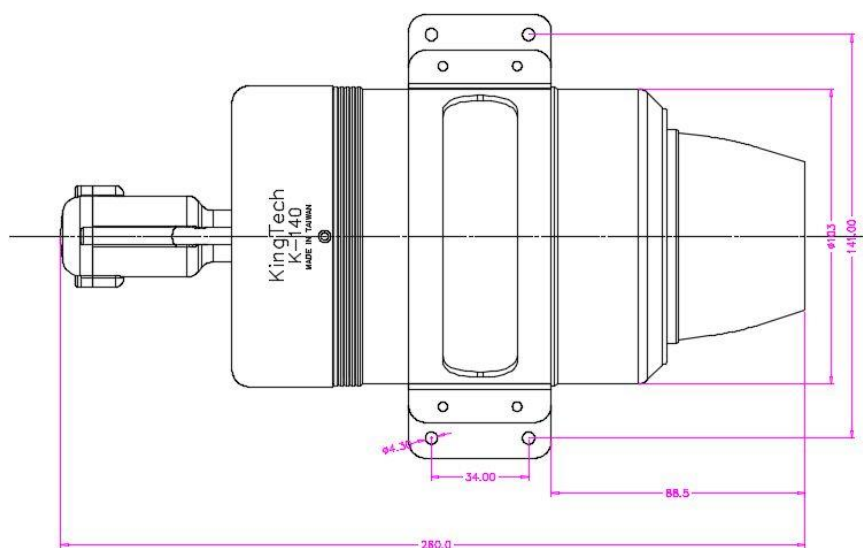

K-160G2 Specifications:

Diameter: 103mm (4.055")

Length: 260mm (10.23") - including starter

Weight: 1460 g (3.5lb.3.5 oz)

RPM Range: 33,000 - 130,000 RPM (up to)

Thrust: 16 kg - 15° C (35 lbs @ 59° F)

Exhaust gas temp: 700°C

Fuel consumption: 490g / min—average (17.28 oz / min)

Oil: 5% (refer to Fuel and Oil/ Fuel Care for restrictions and recommendations)

Fuel: Diesel, Jet-A, Kero

Maintenance cycle: 25 hr USD300

Recommended pump: KP-600V with Priming Valve (Kingtech ECU) KP-600 (Xicoy ECU)

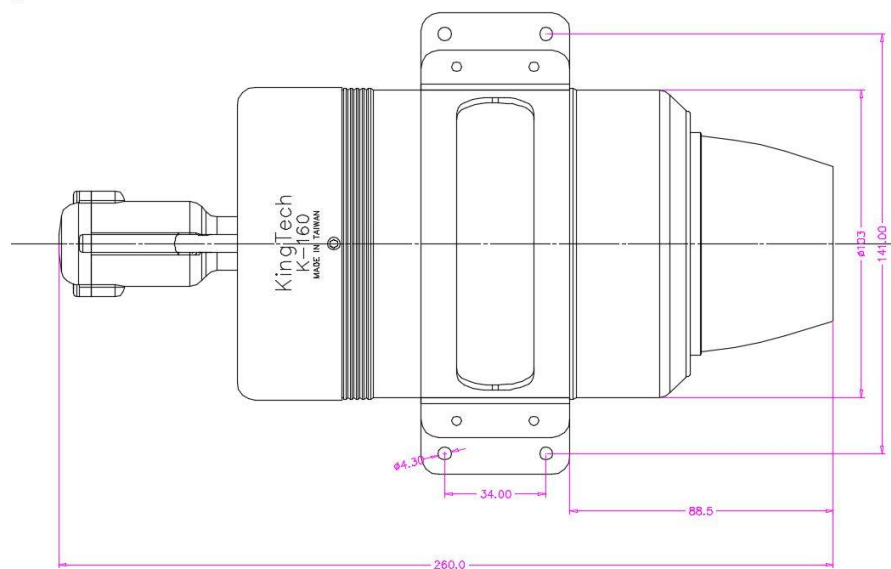

K-180G Specifications:

Diameter: 114mm (4-1/2")

Weight: 1644g (3 lb. 10oz.)

RPM Range: 35,000 - 123,000 RPM (up to)

Thrust: 18 kg or 40 lbs

NGV Temperature: 520°C to 700°C

Fuel consumption: 550g / min (19.4 oz / min)

Lubrication: 5% (refer to Fuel and Oil/ Fuel Care for restrictions and recommendations)

Fuel: Diesel, Jet-A, Kero

Maintenance cycle: 25 hr USD300

Recommended pump: KP-800V with Priming Valve (Kingtech ECU) KP-800 (Xicoy ECU)

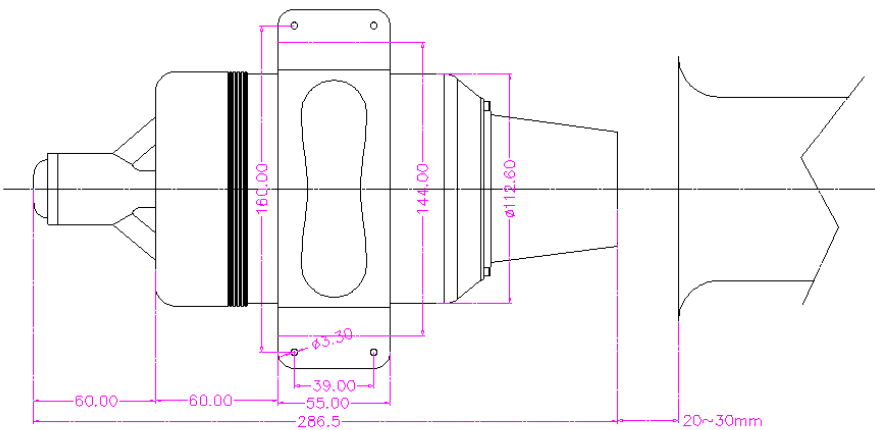

K-210G Specifications:

Diameter: 112.6 mm (4.43")

Length: 286 mm (11.26")

Weight: 1650 g (3 lb. 10oz.)

RPM Range: 33,000-120,000RPM (up to)

Thrust: 21 kg at max RPM (46.3 lbs at max RPM)

EGT: 650°C

Fuel consumption: 590 g / min (20.8 oz / min)

Fuel: Diesel, Jet-A, Kero

Lubrication: 5% (refer to Fuel and Oil/ Fuel Care for restrictions and recommendations)

Maintenance cycle: 25 hr USD300

Recommended pump: KP-800V with Priming (Kingtech ECU) KP-800 (Xicoy ECU)

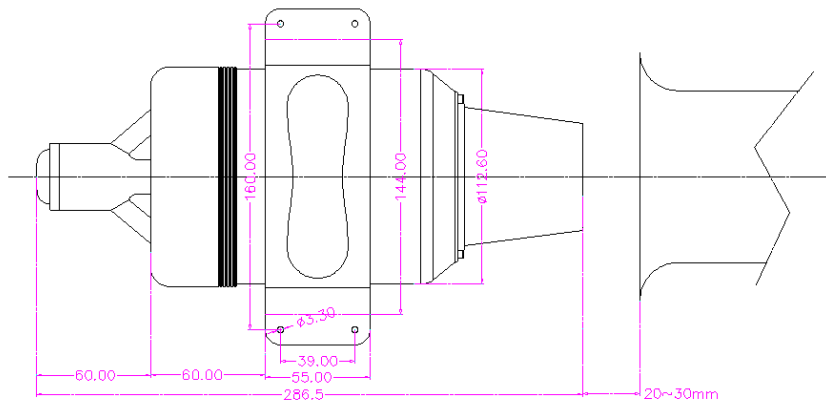

K-310G Specifications:

Diameter: 132.5 mm (5.25")

Length: 335 mm (13.25")

Weight: 2.6kg (5.7lbs.)

RPM Range: 30,000-103,000RPM (up to)

Thrust: 31 kg at max RPM (68.34 lbs at max RPM)

EGT: 700°C

Fuel consumption: 870 g / min

Fuel: Diesel, Jet-A, Kero

Lubrication: 5% (refer to Fuel and Oil/ Fuel Care for restrictions and recommendations)

Maintenance cycle: 25 hr USD300

Recommended pump: KP-800V with Priming (Kingtech ECU)

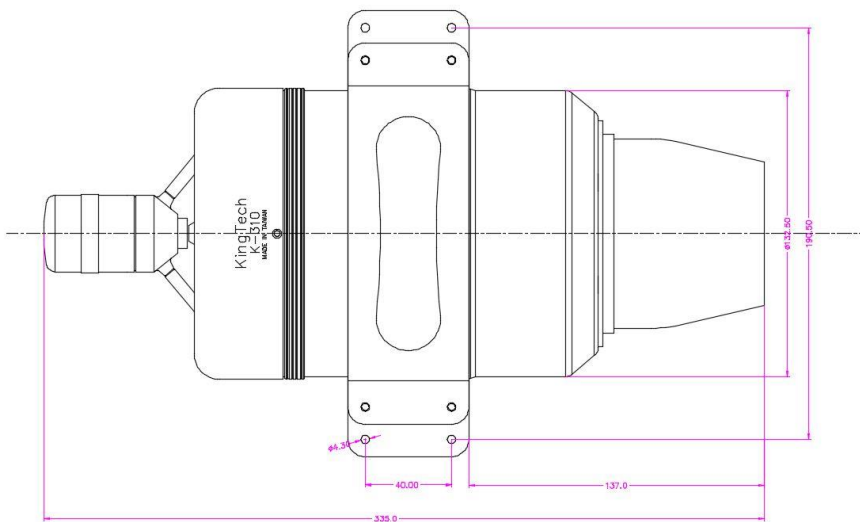

|

Maintenance cycle includes:

- Turbine dismantle
 - Replace of bearings and other components determined by technical staff
 - Balance correction
 - Cleaning of injectors and chamber
 - Turbine assembly
 - Test and adjust if necessary
- |

G Model Series 2 Components List

Engine

Engine Control Unit (ECU)

Ground Support Unit (GSU)

Wiring harness and Tubing set

JR TYPE male to male, throttle

Fuel Pump, Filter and Shutoff Valve

Fuel Inlet Attachments

Manual



KingTech Turbines Fuel Start Operating Guide:

1. Please install engine on a simple stand to familiarize components and starting sequence.
2. For ECU battery pack, use 3S LiFe pack at 9.9V or 7S NiMH at 8.4V, anytime your residual voltage falls under 7.9V the engine may not start.
3. When Learning RC, disconnect ECU battery to avoid initiating a starting sequence
4. If the combustion chamber of the engine is not properly cooled after a fail start, a wet start may or may not occur on the subsequent attempt, please refer to below to avoid a wet start.
5. If and when your engine fails to start, there may still be residual flame and fuel remain in the combustion chamber, please do the following to avoid a wet start:
 - a. Stick Low, Trim Low
 - b. Move Stick forward to activate rotor to further cooling the chamber.
 - c. Wait at least 3 to 5 minutes before resuming
6. Two of the most important parameters for fuel start engines in reference of reducing flame during start up, please consider leaning by decrease value on following parameters, say 10 to 90% from existing:
 - a. Ignition Pump PW
 - b. Preheat Fuel
7. In some cases, if the above #6 does not help enough, one could also do the following:
 - a. Decrease given stage starter power and RPM to facilitate temperature raise.
 - b. Increase given stage starter power and/or RPM to decrease flame.
8. Try to monitor GSU during start up and sight it towards tail cone to take a close look at given stage, whether or not EGT is climbing or flame or fuel dripping is present.

9. During startup, occasional poppy yellow to bluish flame with good velocity is expected and is absolutely normal and healthy; it is the slow orange reddish flame that would be of concern.
10. Before you call-in for tech support on startup, make sure you know which of the three stages that it is or isn't doing what, ie. What temperature it is hanging, any flame or dripping of fuel... Four primary stages of startup: Ignition, Stage 1, Stage 2, Stage 3. It would be a good practice to extend your GSU to be able to view in-line towards the tail cone to watch out for the presence of flame or fuel.

K-60TP Turboprop Operating Guide:

Make sure propeller is well balanced, unbalanced props will cause failure to the Gearbox and airframe, particularly the engine mount and bracket and may cause serious injuries or worse.

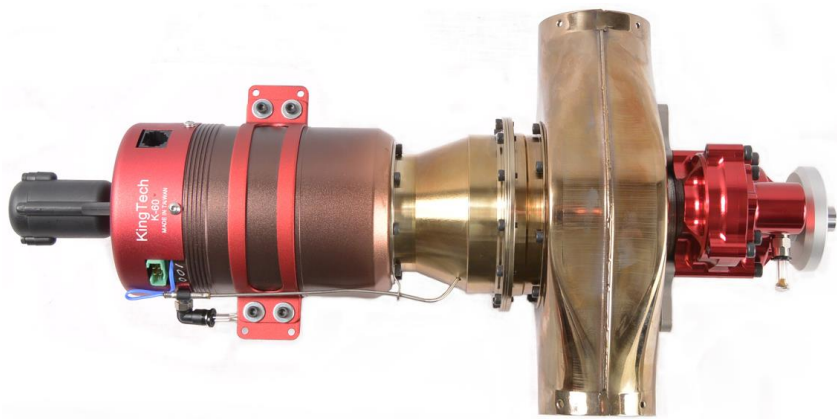

Lubrication tube brackets.



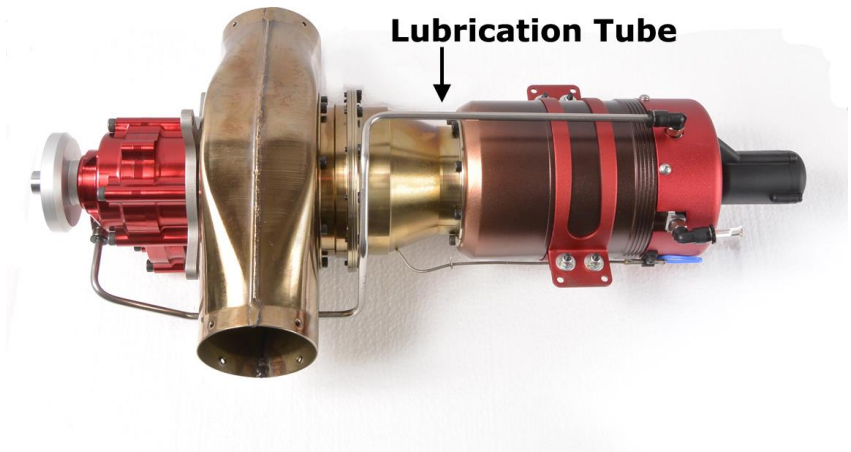



KingTech K-60TP is designed to be running at a high load but low RPM. The ideal prop would be turning at 5000 static and unload only up to 7000RPM. This would ensure max output and longevity of engine. Please use no smaller than 24x16x3b, as it would provide 5500/7500RPM, while a 24x20x3b would achieve the sweet spot of 5000/7000RPM.

RPM	PWR (KW)
2000	3.9
2500	4.6
3000	5.2
3500	5.7
4000	6.1
4500	6.5
5000	6.8
5500	6.9
6000	6.9
6500	7.1
7000	7.3
7500	7.1
8000	7.0
8500	6.4

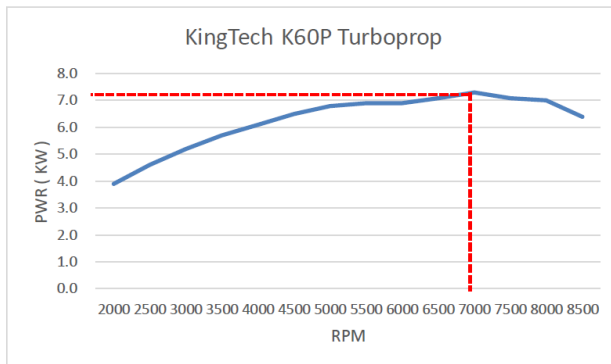

TROUBLESHOOTING

High and Rough Idle –

1. Please relearn RC
2. If relearn RC didn't help, run engine at full RPM, take a look at the value of PW, multiply 1.2, reestablish new pump limit under RUN menu and relearn RC.
3. If above didn't help either, you may have a fuel pump problem, please send it in for evaluation.

ECU Fails to Learn RC

Go to the radio screen, Page 1 of 6 on the GSU and make sure you have a reading on "RX: xxx μ s " when the TX is set in the 3 relevant positions (stop, idle, full power).

If Zero, then it is most likely a hardware problem. The throttle lead may be damaged or in the wrong port or the ECU or Receiver is defective.

If same reading is in all 3 positions, the throttle lead is connected in the wrong channel on the Receiver.

If not zero then you should check the value of the readings.

STOP should be between 900 μ s and 1000 μ s, Idle should be between 1200 μ s and 1400 μ s and full power should be between 1900 μ s and 2100 μ s

Idle should be in between STOP and Full, at least 100 μ s higher than STOP position and 500 μ s lower than full power position, and be stable, same readings should be obtained after resetting the TX and in all flight modes. For example, an AUTOTRIM function will center the trim each power up, changing the IDLE position.

Readings outside these limits mean an improper setup on the transmitter, and should be corrected on transmitter. Your ATV settings on the throttle channel need to be set to 100% and -100%.

If all of these items are correct, the Learn RC process may have been done incorrectly.

The usual failures done during procedure are not using the "+" key to confirm the position, or skipping one step, or raising the stick before the trim, some model set ups have a security function for electric flight where the stick is disabled if the trim is not raised first, to prevent sudden startup of electric motors that can injure the operator.

CONTACT INFORMATION

KingTech Turbines International

289 S SANTA ANITA AVE
PASADENA CA 91107
United States

Email Sales and Support: kingtechturbines@gmail.com
Email Administrative Only: mail@kingtechturbines.com
Website: www.kingtechturbines.com

Emergency Support: Barry's Cell: 626-399-7588 [talk/text](#)
Skype: [barrymhou](#)
Line: [barryhou1](#)

Emergency Support: Dirk's Cell: 626-808-6122 [talk/text](#)

Engine Model: _____

Serial Number: _____

* Before you call for tech support, make sure your engine is properly registered at www.kingtechturbines.com and with above information ready.

* When sending in an engine for service, please make sure you have included at least the ECU and a Service Request Form (following page or www.kingtechturbines.com) filled out, or [you will compromise your service priority. Completed service request forms ensure that your turbine is serviced and diagnosed correctly. Information passed verbally in person or over the phone does not become part of the permanent record.](#)

* When checking up on status of an engine sent in for service, do not call, please email with history and serial number of engine. Do not call to see if we have received the engine, you have that information through tracking.

KingTech Turbines Co., Ltd.

No.198, Ln. 818, Gongxing Rd.
Pingtung City, Pingtung County 90086
TAIWAN

886-8-751-0065 ([This is an International call. Check with your provider for additional charges](#))

For additional information on the ECU, please go to:

<http://www.espiell.com/FAD10.pdf>

Revision Date: Aug. 2015, 15th Edition

Engine sent in without this form will not be serviced until supplied

Glossary

- [ECU](#) – Engine Control Unit (Detail description on Description of the ECU)
- EGT – Exhaust Gas Temperature
- [FADEC](#) – Full Authority Digital Engine Control. This is another term for ECU.
- [GSU](#) – Ground Support Unit. The KingTech Series 2 GSU is an LCD touch screen display that allows for viewing of turbine operation values and allows for access to other maintenance, setup and troubleshooting functions. Note: the Series 2 GSU is only compatible with a KingTech Series 2 ECU.
- [RX](#) – Radio receiver. The device in your RC Aircraft that receives radio signals from your transmitter and acts a connection and control point for servos and other devices such as your turbine.
- [TX](#) – Radio transmitter that has control inputs such as levers, dials and switches which send control inputs via radio wave transmission to the Radio Receiver in the RC Aircraft.
- [UAT](#) – Universal Air Trap. This device eliminates air bubbles from entering the fuel line leaving the fuel supply tanks before they enter the fuel pump and turbine causing a likely flameout.
- μs – This is the symbol for microseconds. A microsecond is equal to one millionth of a second.

